

PNEUMATIC TOOL PARTS LIST

■ PIN NAILER
Model NP 50A

2018 • 11 • 07
(E1)

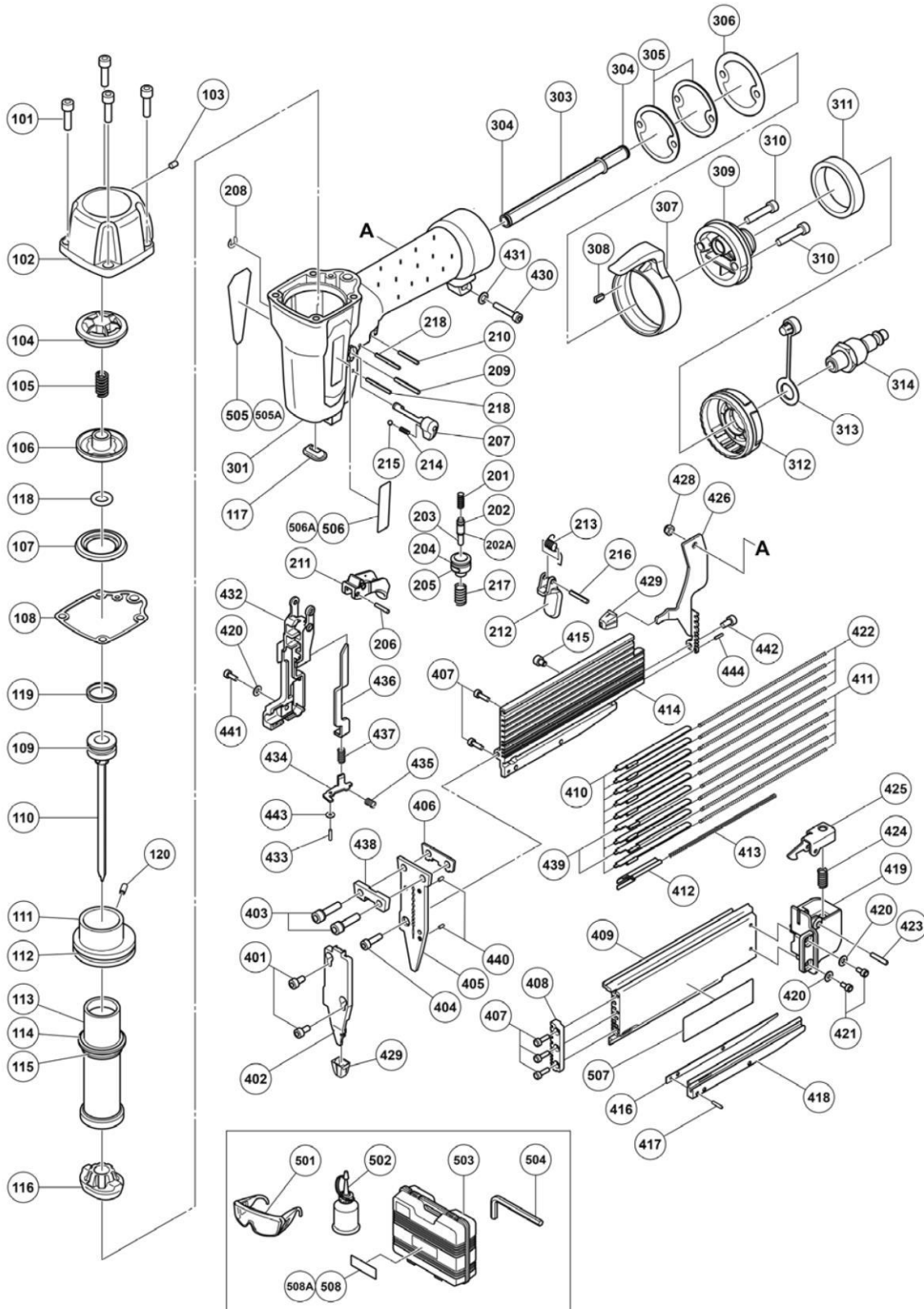

PARTS

NP50A

ITEM NO.	CODE NO.	DESCRIPTION	NO. USED	REMARKS
101	889544	M5 X 20 HEX SOCKET SCREW	4	
102	889545	HEAD COVER	1	
103	889546	M4 X 6 SET SCREW	1	
104	889547	COLLAR	1	
105	889548	VALVE PISTON SPRING	1	
106	889549	VALVE PISTON	1	
107	889550	SEAL	1	
108	889551	HEAD COVER SEAL	1	
109	889552	O RING(B)	1	
110	889553	DRIVER UNIT	1	
111	889554	CYLINDER SPACER	1	
112	889555	O RING (C)	1	
113	889556	CYLINDER	1	
114	889557	O RING (D)	1	
115	889558	O RING (E)	1	
116	889559	BUMPER	1	
117	889560	JOINT GUIDE	1	
118	889561	O RING (A)	1	
119	889562	PISTON RING	1	
120	890158	SPRING PIN	1	
201	889563	SPRING (B)	1	
202	889564	O RING (G)	1	
202A	889594	O RING (H)	1	
203	889565	PLUNGER	1	
204	889566	O RING (J)	1	
205	889567	PLUNGER CAP	1	
206	889568	PIN (A)	1	
207	889569	LOCK KNOB	1	
208	889570	RETAINING RING E	1	
209	889571	D3 X 25 ROLL PIN	1	
210	889572	D2.5 X 20 ROLL PIN	1	
211	889573	TRIGGER	1	
212	889574	LOCK LEVER	1	
213	889575	LOCK LEVER SPRING	1	
214	889576	SPRING (A)	1	
215	889577	STEEL BALL	1	
216	889578	D3 X 18 ROLL PIN	1	
217	889579	SPRING (C)	1	
218	889580	D2.5 X 25 ROLL PIN	2	
301	889581	BODY	1	
303	889582	LINK ROD	1	
304	889583	O RING (F)	2	
305	889584	GASKET (A)	2	
306	889585	GASKET (B)	1	
307	889586	HOOK	1	
308	889587	RUBBER PAD	1	
309	889588	END CAP	1	
310	889589	M5 X 20 HEX SOCKET SCREW	2	
311	889590	MUFFLER	1	
312	889591	EXHAUST COVER	1	
313	889592	AIR PLUG CAP	1	
314	889593	AIR PLUG	1	
401	889595	M4 X 8 HEX SOCKET SCREW	2	
402	889596	DRIVER GUIDE COVER (A)	1	
403	889597	M5 X 20 HEX SOCKET SCREW	2	
404	889598	M4 X 14 HEX SOCKET SCREW	1	
405	889599	DRIVER GUIDE	1	
406	889600	GASKET (C)	1	
407	889601	M3 X 10 HEX SOCKET SCREW	5	
408	889602	FIXED SUPPORT	1	
409	889603	MAGAZINE (B)	1	
410	889604	STOPPER (A)	7	
411	889605	STOPPER SPRING (A)	5	

STANDARD ACCESSORIES

N50PA

ITEM NO.	CODE NO.	DESCRIPTION	NO. USED	REMARKS
501	875769	EYE PROTECTION	1	
502	877153	OIL FEEDER	1	
503	889639	CASE	1	
504	943277	HEX. BAR WRENCH 4MM	1	
508		CASE BRAND LABEL (H)	1	HITACHI BRAND
508A		CASE BRAND LABEL (M)	1	METABO HPT BRAND

OPTIONAL ACCESSORIES

ITEM NO.	CODE NO.	DESCRIPTION	NO. USED	REMARKS
	115338	ALL WEATHER TOOL OIL, 4OZ.		12 PER MATER CASE
	877153	OIL FEEDER, .8OZ.		
	876212	OIL 1 QUART CAN		

