

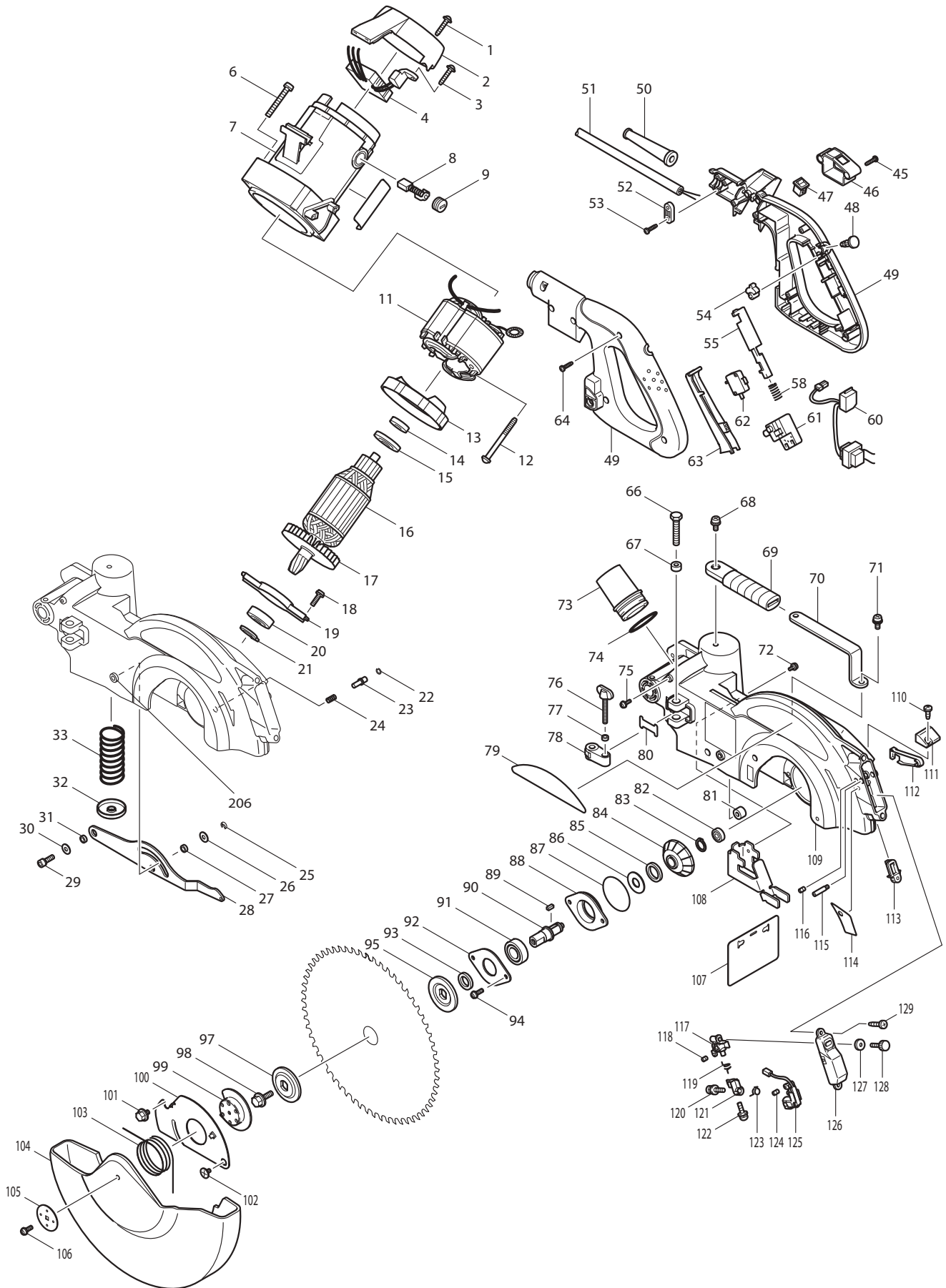

03-2010
LS1013L

10" COMPOUND MITRE SAW W/LASER

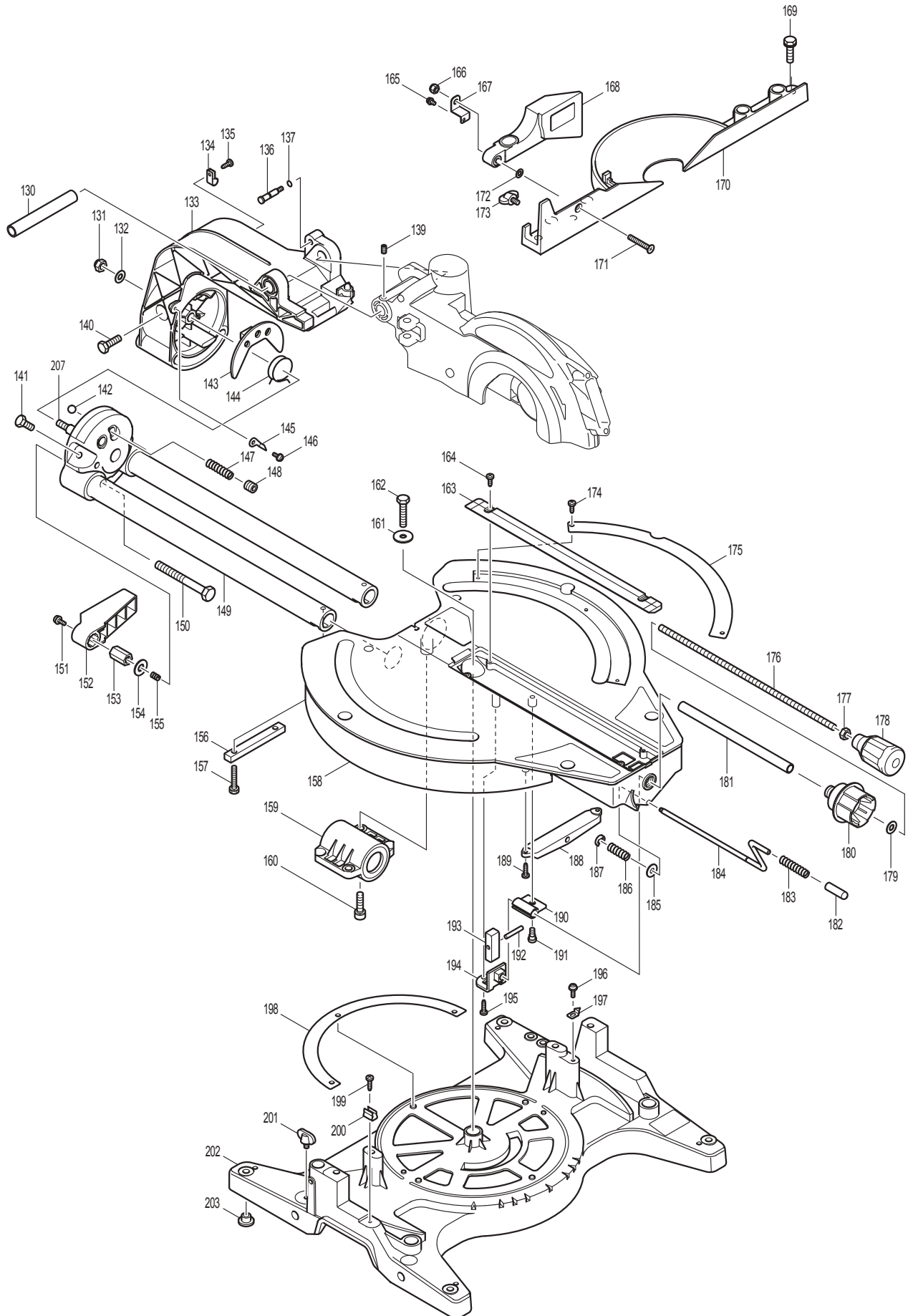



Item No.	Type	Sub	Part No.	Description (*see Service changes on the bottom)	Qty	Unit
1			265995-6	TAPPING SCREW 4X18	2	PC.
2			416075-3	REAR COVER	1	PC.
3			265995-6	TAPPING SCREW 4X18	1	PC.
4			631218-8	CONTROLLER	1	PC.
6			911373-5	PAN HEAD SCREW M6X50	4	PC.
7			154720-9	MOTOR HOUSING COMPLETE	1	PC.
		INC.	643660-1	BRUSH HOLDER 6.5-13.5	2	PC.
		INC.	810642-0	CAUTION LABEL	1	PC.
		INC.	810969-8	CAUTION LABEL	1	PC.
8	1		181047-4	CARBON BRUSH CB-154 2PC/SET (W/O ORIGIN)	1	SET
	2		194986-9	CARBON BRUSH CB-154 2PC/SET (W/ ORIGIN)	1	PC.
9			643650-4	BRUSH HOLDER CAP 6.5-13.5	2	PC.
11			596141-3	FIELD ASS'Y 115V	1	PC.
		INC.	654020-2	RING TERMINAL	2	PC.
		INC.	654502-4	CONNECTOR P-2	2	PC.
12			266029-8	TAPPING SCREW 5X65	2	PC.
13			416107-6	BAFFLE PLATE	1	PC.
14			211061-7	BALL BEARING 6000LLB	1	PC.
15			681642-5	INSULATION WASHER	1	PC.
16			516926-1	ARMATURE ASS'Y 115V	1	PC.
		INC.		Item No. 14,15,17		
17			240001-8	FAN 80	1	PC.
18			911223-4	PAN HEAD SCREW M5X16	2	PC.
19			285686-3	BEARING RETAINER 94	1	PC.
20			211275-8	BALL BEARING 6003DDW	1	PC.
21			961057-5	RETAINING RING S-17	1	PC.
22			231928-3	RING SPRING 8	1	PC.
23			256633-1	PIN 6	1	PC.
24			231240-1	COMPRESSION SPRING 7	1	PC.
25			961018-5	STOP RING E-5	1	PC.
26			253804-1	FLAT WASHER 6	1	PC.
27			257163-5	RING 6	1	PC.
28			345604-4	LINK PLATE	1	PC.
29			922331-6	HEX. SOCKET HEAD BOLT M6X20	1	PC.
30			253804-1	FLAT WASHER 6	1	PC.
31			257163-5	RING 6	1	PC.
32			344464-1	SPRING HOLDER	1	PC.
33			233461-1	COMPRESSION SPRING 28	1	PC.
45			265995-6	TAPPING SCREW 4X18	2	PC.
46			154541-9	SWITCH BOX COMPLETE	1	PC.
		INC.	817540-9	LASER BEAM LABEL	1	PC.
47			651522-9	SWITCH SLE6A	1	PC.
48			411478-6	SWITCH BUTTON	1	PC.
49			183980-6	HANDLE SET	1	SET
50			682505-8	CORD GUARD 10-90	1	PC.
51			664463-0	CORD W/PLUG 2P-14-2.5M, SJ	1	PC.
52			687052-4	STRAIN RELIEF	1	PC.
53			265995-6	TAPPING SCREW 4X18	2	PC.
54			414546-4	CAM	1	PC.
55			416000-4	LOCK OFF LEVER	1	PC.
58			231457-6	COMPRESSION SPRING 3	1	PC.
60			631576-2	POWER SUPPLY CIRCUIT	1	PC.
61			651923-1	SWITCH TG70B	1	PC.
62	Opt.		651941-9	SWITCH (for High Voltage 220V) - Optional Only*	1	PC.

*This item is only for high voltage 220V machine to prevent damage of brake winding.
Not necessary for Canadian model.

Item No.	Type	Sub	Part No.	Description (*see Service changes on the bottom)	Qty	Unit
63			415999-0	SWITCH LEVER	1	PC.
64			265995-6	TAPPING SCREW 4X18	8	PC.
66			921467-8	HEX. BOLT M8X45	1	PC.
67			262003-4	RUBBER RING 6	1	PC.
68			911323-0	PAN HEAD SCREW M6X16	1	PC.
69			421562-9	GRIP	1	PC.
70			344420-1	GRIP HOLDER	1	PC.
71			911323-0	PAN HEAD SCREW M6X16	1	PC.
72			911114-9	PAN HEAD SCREW M4X10	1	PC.
73			419277-0	DUST NOZZLE	1	PC.
74			213460-9	O RING 35	1	PC.
75			911113-1	PAN HEAD SCREW M4X10	1	PC.
76			265717-4	SCREW M6X43	1	PC.
77			262001-8	URETHANE RING 5	1	PC.
78			317176-9	STOPPER ARM	1	PC.
79			819214-8	MAKITA LOGO LABEL	1	PC.
80			344045-1	STOPPER ARM PLATE	1	PC.
81			421952-6	CUSHION	1	PC.
82			211021-9	BALL BEARING 607LLB	1	PC.
83			961054-1	RETAINING RING S-14	1	PC.
84			226742-0	SPIRAL BEVEL GEAR 33	1	PC.
85			262074-1	RUBBER RING 20	1	PC.
86			267035-6	FLAT WASHER 14	1	PC.
87			213673-2	O RING 52	1	PC.
88			316836-0	BEARING BOX (A)	1	PC.
89			254202-2	KEY 4	1	PC.
90			322899-6	SPINDLE	1	PC.
91			211275-8	BALL BEARING 6003DDW	1	PC.
92			285828-9	BEARING RETAINER 66	1	PC.
93			257060-5	RING 15.8	1	PC.
94			911223-4	PAN HEAD SCREW M5X16	2	PC.
95			224333-1	FLANGE 53	1	PC.
97			224333-1	FLANGE 53	1	PC.
98			265355-2	HEX. FLANGE HEAD BOLT M8X20	1	PC.
99			344473-0	CENTER PLATE	1	PC.
100			345603-6	CENTER COVER	1	PC.
101			265324-3	HEX. FLANGE HEAD BOLT M8X12	1	PC.
102			265008-3	+ FLAT HEAD SCREW K5	1	PC.
103			231613-8	TORSION SPRING 45	1	PC.
104			419073-6	SAFETY COVER	1	PC.
105			253977-0	FLAT WASHER 6	1	PC.
106			911218-7	PAN HEAD SCREW M5X14	1	PC.
107			421916-0	GUARD	1	PC.
108			345610-9	GUARD PLATE	1	PC.
109			188027-1	BLADE CASE SET	1	PC.
		INC.	810106-4	LASER BEAM CAUTION LABEL	1	PC.
		INC.	817874-0	CAUTION LABEL	1	PC.
		INC.	816847-0	OPERATIONAL INDICATION LABEL	1	PC.
		INC.	810124-2	LASER BEAM CAUTION LABEL	1	PC.
		INC.		Item No. 79		
110			266026-4	TAPPING SCREW BIND CT 4X12	1	PC.
111			419078-6	LEAD COVER HOLDER	1	PC.
112			419076-0	LEAD COVER	1	PC.
113			418104-8	LENS	1	PC.

Item No.	Type	Sub	Part No.	Description (*see Service changes on the bottom)	Qty	Unit
114	1		801262-1	* LASER LABEL	1	PC.
	2		804293-9	* LASER LABEL	1	PC.
115			266306-8	SHOULDER SCREW M5	1	PC.
116			266229-0	H.S.SET SCREW(CUP POINT)M5X8	2	PC.
117	1		418107-2	* BLOCK C	1	PC.
	2		419379-2	* BLOCK C	1	PC.
118			266318-1	H.S.SET SCREW(FLAT POINT)M4X6	1	PC.
119			231664-1	TORSION SPRING 9	1	PC.
120	1		911014-3	* PAN HEAD SCREW M3X10	1	PC.
	2		911003-8	* PAN HEAD SCREW M3X6	1	PC.
121	1		418106-4	* BLOCK B	1	PC.
	2		419378-4	* BLOCK B	1	PC.
122	1		911014-3	* PAN HEAD SCREW M3X10	1	PC.
	2		911003-8	* PAN HEAD SCREW M3X6	1	PC.
123			231664-1	TORSION SPRING 9	1	PC.
124			266318-1	H.S.SET SCREW(FLAT POINT)M4X6	1	PC.
125	1		638356-7	* LASER CIRCUIT COMPLETE - N/L/A	1	PC.
	2		638442-4	* LASER CIRCUIT COMPLETE	1	PC.
126	1		418108-0	* TOP COVER	1	PC.
	2		419380-7	* TOP COVER	1	PC.
127			253807-5	FLAT WASHER 5	1	PC.
128			265753-0	THUMB SCREW M5X24	1	PC.
129			266042-6	TAPPING SCREW BIND CT 4X20	2	PC.
130			331428-4	PIPE 16-113	1	PC.
131			252105-4	HEX. LOCK NUT M8-13	1	PC.
132			941201-0	FLAT WASHER 8	1	PC.
133			154779-6	ARM COMPLETE	1	PC.
		INC.	816787-2	INDICATION LABEL	1	PC.
134			687095-6	STRAIN RELIEF	1	PC.
135			266026-4	TAPPING SCREW BIND CT 4X12	1	PC.
136			322317-4	STOPPER PIN	1	PC.
137			213021-5	O RING 5	1	PC.
139			251961-9	H.S.SET SCREW(FLAT POINT)M6X10	1	PC.
140			265371-4	HEX. BOLT M8X30	2	PC.
141			265412-6	HEX. BOLT M8X20	2	PC.
142			216003-6	STEEL BALL 10	2	PC.
143			345418-1	GUIDE PLATE	1	PC.
144			231626-9	TORSION SPRING 28	1	PC.
145			413067-3	INDICATION PLATE	2	PC.
146			911114-9	PAN HEAD SCREW M4X10	2	PC.
147			233168-9	COMPRESSION SPRING 5	2	PC.
148			266131-7	H.S.SET SCREW(FLATPOINT)M12X12	2	PC.
149			151459-5	ARM HOLDER COMPLETE	1	PC.
		INC.	816771A7	BEVEL SCALE LABEL (OLD#816771-7 - N/L/A)	1	PC.
150			251668-7	HEX. BOLT M10X90	1	PC.
151			911113-1	PAN HEAD SCREW M4X10	1	PC.
152			416006-2	LEVER 100	1	PC.
153			252144-4	HEX. NUT M10-17	1	PC.
154			253024-7	FLAT WASHER 10	1	PC.
155			231266-3	COMPRESSION SPRING 5	1	PC.
156			152542-1	SQUARE ROD COMPLETE	1	PC.
		INC.	263005-3	RUBBER PIN 6	1	PC.
157			921356-7	HEX. BOLT M6X35	2	PC.

Item No.	Type	Sub	Part No.	Description (*see Service changes on the bottom)	Qty	Unit
158			153832-5	TURN BASE COMPLETE	1	PC.
		INC.	211444-1	LINEAR BALL BEARING 3064	1	PC.
		INC.	219002-7	BEARING 30	1	PC.
		INC.	262048-2	FELT RING 30	2	PC.
		INC.	263005-3	RUBBER PIN 6	1	PC.
		INC.	343676-3	CAP	1	PC.
		INC.	817283-3	CAUTION LABEL	2	PC.
159			152540-5	BEARING BOX B COMPLETE	1	PC.
		INC.	211444-1	LINEAR BALL BEARING 3064	1	PC.
		INC.	262048-2	FELT RING 30	2	PC.
		INC.	343676-3	CAP	2	PC.
		INC.	316837-8	BEARING BOX (B)	1	PC.
160			922451-6	HEX. SOCKET HEAD BOLT M8X30	2	PC.
161			253852-0	FLAT WASHER 8	1	PC.
162			265442-7	HEX. BOLT M8X40	1	PC.
163			419222-5	KERF BOARD, BLUE	2	PC.
164			266026-4	TAPPING SCREW BIND CT 4X12	4	PC.
165			911108-4	PAN HEAD SCREW M4X8	1	PC.
166			252014-7	HEX. LOCK NUT M6-10	1	PC.
167			344463-3	SUB FENCE PLATE	1	PC.
168			150711-8	SUB FENCE COMPLETE	1	PC.
		INC.	810858-7	CAUTION LABEL	1	PC.
169	1		265488-3	* HEX. BOLT M8X30	4	PC.
	2		921451-3	* HEX. BOLT M8X30	4	PC.
170			316840-9	GUIDE RULE	1	PC.
171			912357-6	COUNTERSUNK HEAD SCREW M6X35	1	PC.
172			253715-0	FLAT WASHER 6	1	PC.
173			251887-5	SCREW M6X10	1	PC.
174			266026-4	TAPPING SCREW BIND CT 4X12	2	PC.
175			816326A8	MITER SCALE PLATE (OLD#816326-8 - N/L/A)	1	PC.
176			266132-5	SCREW M8X320	1	PC.
177			931402-8	HEX. NUT M8	1	PC.
178			271314-6	GRIP 40	1	PC.
179			941201-0	FLAT WASHER 8	1	PC.
180			152541-3	KNOB 48 COMPLETE	1	PC.
181			331491-7	PIPE 9-200	1	PC.
182			421563-7	CAP 10	1	PC.
183			322924-3	COIL SPRING	1	PC.
184			322909-9	LOCK PIN	1	PC.
185			253804-1	FLAT WASHER 6	1	PC.
186			231307-5	COMPRESSION SPRING 6	1	PC.
187			961018-5	STOP RING E-5	1	PC.
188			316899-6	PIN HOLDER	1	PC.
189			266034-5	TAPPING SCREW CT 4X16	2	PC.
190			344411-2	SLIDE STOPPER	1	PC.
191			251267-5	+ PAN HEAD SCREW L6	1	PC.
192			256196-7	PIN 5	1	PC.
193			331493-3	TURN STOPPER	1	PC.
194			344412-0	STOPPER HOLDER	1	PC.
195			266034-5	TAPPING SCREW CT 4X16	1	PC.
196			266026-4	TAPPING SCREW BIND CT 4X12	1	PC.
197			816128-2	POINTER	1	PC.
198			344477-2	SLIDE PLATE	2	PC.
199			266034-5	TAPPING SCREW CT 4X16	1	PC.
200			232075-3	LEAF SPRING	1	PC.
201			251887-5	SCREW M6X10	2	PC.
202			153837-5	BASE COMPLETE	1	PC.
		INC.	817838-4	CAUTION LABEL	1	PC.

Item No.	Type	Sub	Part No.	Description (*see Service changes on the bottom)	Qty	Unit
203			286212-1	CAP 20	4	PC.
204			941202-8	* FLAT WASHER 8 (Added)	4	PC.
205			233471-8	* COMPRESSION SPRING 6 (Added)	1	PC.
206			322316-6	LINK SHAFT (F/BLADE CASE COM.) (Special Order Item)	1	PC.
207			322912-0	CENTER SHAFT (F/ARM HOLDER COM.) (Special Order Item)	1	PC.

ACCESSORIES

- See catalogue or visit www.makita.ca for other optional accessories -

A01	1		122523-9	DUST BAG ASS'Y	1	PC.
		INC.	410602-8	FASTENER	1	PC.
	2		122852-0	DUST BAG ASS'Y	1	PC.
		INC.	410602-8	FASTENER	1	PC.
A02			122538-6	WISE ASS'Y	1	PC.
		INC.	251370-2	+ PAN HEAD SCREW I5	1	PC.
		INC.	251887-5	SCREW M6X10	1	PC.
		INC.	253804-1	FLAT WASHER 6	1	PC.
		INC.	271309-9	KNOB 40	1	PC.
		INC.	316898-8	WISE ARM	1	PC.
		INC.	322983-7	WISE ROD	1	PC.
		INC.	343651-9	WISE PLATE	1	PC.
A03			411478-6	SWITCH BUTTON	2	PC.
A04			762001-3	TRIANGULAR RULE	1	PC.
A05			783208-8	HEX. WRENCH 2.5	1	PC.
A06			322932-4	HOLDER 255	2	PC.
A07	1		721414-A	10" C.T.SAW BLADE 64T	1	PC.
	2		A-93550	10" C.T.SAW BLADE 70T	1	PC.
A08			782212-4	SOCKET WRENCH 13	1	PC.
A09			122470-4	HORIZONTAL VISE ASSY	1	PC.
		INC.	271297-0	KNOB 45	1	PC.
		INC.	344099-8	GUARD PLATE	1	PC.
		INC.	253744-3	FLAT WASHER 12	1	PC.
		INC.	253047-5	FLAT WASHER 6	1	PC.
		INC.	911317-5	P.H.SCREW M6X14	1	PC.
		INC.	286236-7	CAP 16	2	PC.
		INC.	322209-7	VICE NUT	1	PC.
		INC.	154431-6	VICE AREM COM. (special order item)	1	PC.
		INC.	316952-8	VICE PLATE (special order item)	1	PC.
A10			194002-7	SUB FENCE R COM.	1	PC.
		INC.	251887-5	SCREW M6X10	2	PC.
A11			192628-9	CROWN STOPPER	2	SET
A12			416368-8	ELBOW	1	PC.
A13			191687-A	MAKITA SAFETY GLASS (OLD# 191686-A - N/L/A)		PC.
A14			193051-1	KERF BLOCK SET	1	SET
		INC.	251314-2	+ SCREW M4X12	2	PC.
A15			194061-1	MITRE SAW STAND - See Partsbreakdown 194061-1	1	PC.
A16			194943-7	SLIDE MITRE SAW STAND - See Partsbreakdown 194943-7	1	PC.
A17			194175-6	DUST BOX - See Partsbreakdown 194175-6		

SERVICE CHANGES

1. Changes on Laser Parts

Item No.	Description	Type 1	Type 2
114	Laser Label	801262-1	804293-9
117	Block C	418107-2	419379-2
120, 122	P.H.Screw	911014-3	911003-8
121	Block B	418106-4	419378-4
125	Leser Circuit Com.	638356-7	638442-4
126	Top Cover	418108-0	419380-7
205	Compression spring	-----	233471-8

Above parts are completely interchangeable as a set.

Fig.1





	Item No.125	Item No. 121	Item No. 117	P.H.Screw M3 for Block B
Type1				With a wave washer and a large flat washer. The screw length 10mm
Type2				With a wave washer and a small flat washer. The screw length 6mm

Fig.2

Item No. 126

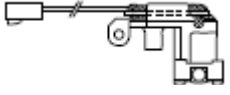
A threaded hole is added

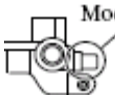

Fig.3

Item No. 114

A hole is disappeared



Fig.4

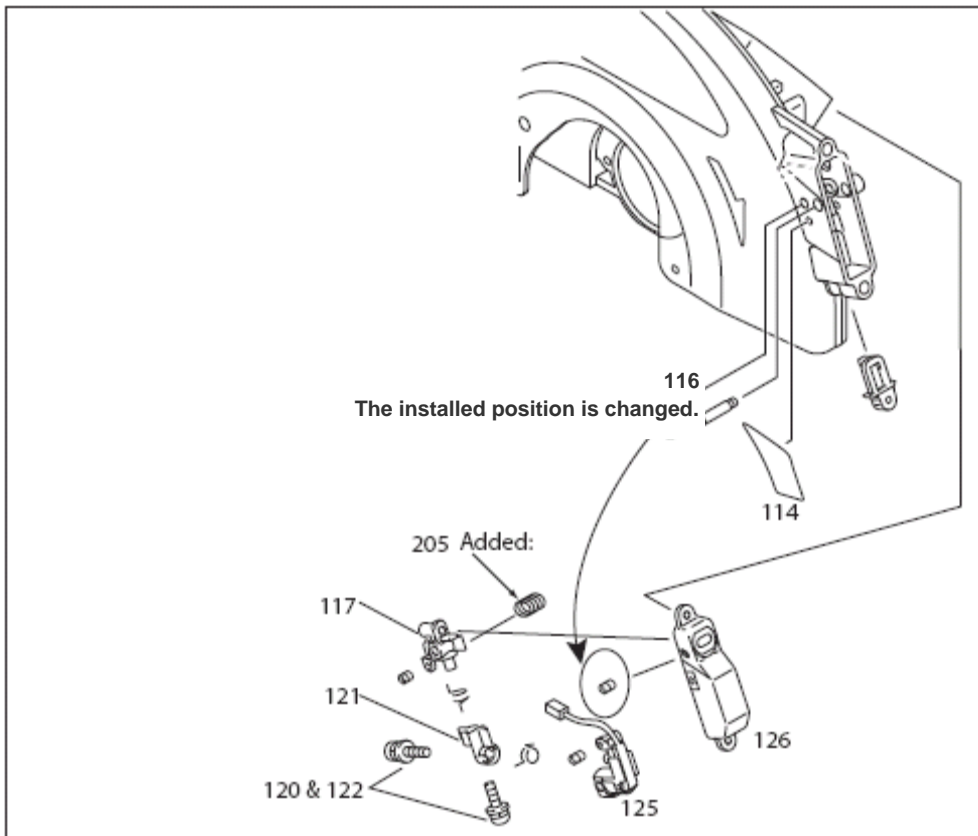

SERVICE CHANGES

2. Changes on Hex. Bolt and Addition of Flat washer

Item No.	Description	Type 1	Type 2
169	HEX. BOLT M8X30	265488-3	921451-3
204	Flat washer	-----	941202-8

Above parts are completely interchangeable as a set.

