

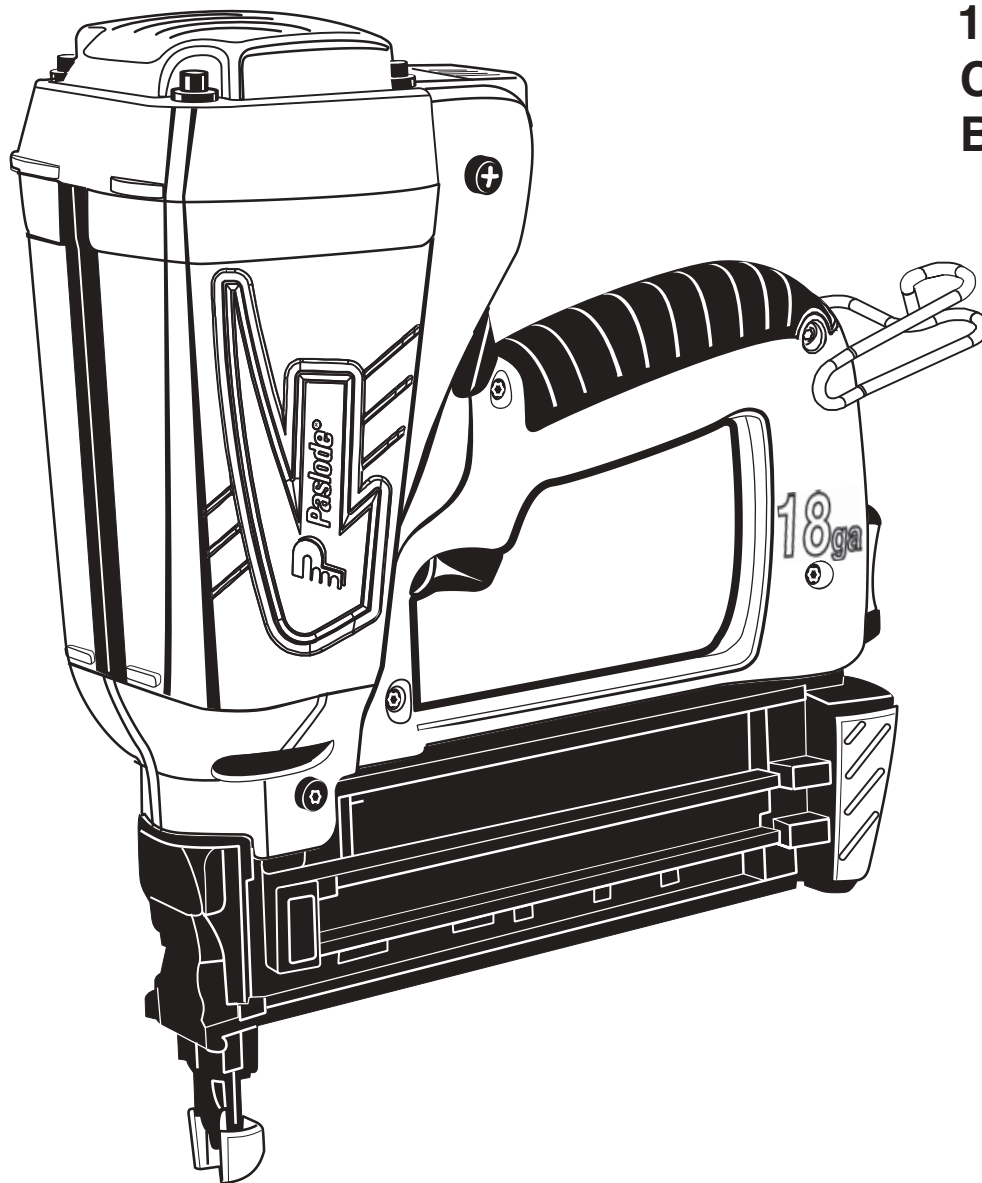

Part No. 903700

**IM200Li
18 Gauge
Cordless
Brad Nailer**



**IMPORTANT!
DO NOT DESTROY**

Always refer to operators manual for detailed information on this tool. It is the customers responsibility to have all operators and service personnel read and understand this information.

TOOL SCHEMATIC AND PARTS

PARTS LEGEND

IM200Li 18 Ga. Cordless Brad Nailer 903700

1	900801	1	Grille, Black	52	901032	2	Bushing, Handle
* 2	900648	1	Filter	53	901095	1	Switch Side Assembly
3	901064	4	S.H.C.S. 8-32 x 1-3/8"	* 54	404922	2	Battery Contact Pad
4	902011	1	Cap, Black	55	918001	1	Label, Name Plate
5	901119	1	Retaining Ring	56	903505	1	Label, Logo Right Side
6	901382	1	Fan Motor Assembly with ring	57	902416	1	Depth of Drive Indicator
7	401356	1	Motor Sleeve	58	903506	1	Label, Left Side
8	900785	1	Spark Plug Sleeve	59	902434	1	Nut, Utility Hook
* 9	900714	1	Spark Plug Assembly	60	902430	1	Button, Utility Hook
10	900674	1	Wire Clip	61	902431	1	Block, Utility Hook
11	900605	1	Cylinder Head	62	902432	1	Spring
* 12	900697	1	Stem Adapter	63	902435	1	Stop
13	900596	1	Screw, Sem 8-32 x 7/16"	64	902430	1	Utility Hook
14	900739	1	Cylinder Head Circuit Board Assembly	65	901036	1	Retaining Ring
15	900612	4	Seal Ring	66	901040	1	Piston Ring
16	900709	1	Fan Assembly	* 67	901078	1	Piston Assembly
17	900700	1	Air Dam	68	901044	1	Soft Grip
18	900729	1	Combustion Chamber Assy.	69	900662	1	ESU Power Wire Assembly
19	900746	2	Screw 8-32 x 7/16 phtx	70	902440	1	Electronic Spark Unit
20	901038	1	Spring	71	901045	1	Trigger
21	901037	1	Yoke	72	901047	1	Trigger Pin
22	901039	1	Yoke Support	73	901053	1	Trigger Spring
23	903726	1	Yoke Guide & Knob Assy.	74	900629	1	HighTension Clip
24	903710	1	Knob Assembly	75	404702	1	Screw 6-32 x 3/8"
25	901009	1	Latch Cover Quick Clear	76	900663	1	Fan Wire Assembly
26	900685	1	Spring Pin	77	903728	1	Spark Plug Wire Assembly
27	901005	1	Latch Clip	78	902439	1	Molded Circuit Assembly
28	901049	1	Spring Pin	79	901019	1	Torsion Spring, Magazine Latch
29	901006	1	Spring Clip Assembly	80	900353	1	Pivot Pin
30	901002	1	Front Plate	81	901014	1	Magazine Latch Release
* 31	901048	1	Probe Tip	82	901061	2	Screw 6-32 x 3/16 BH
32	903704	1	Probe	83	901013	1	Magazine End Cap
33	901026	2	Screw 10-24 x .75	84	901084	1	Magazine Wear Strip Assembly
34	901003	1	Back Plate	■ 85	900660	2	Screw 10-32 x 3/8"
35	901025	1	Support Pin	86	901012	1	Magazine Cover
36	901004	1	Front Plate Support	87	901015	1	Follower
37	901081	1	Sleeve Assembly	88	901018	1	Magazine Pin
38	405140	4	Screw 8-32 x 7/16" (red)	* 89	901055	1	O-ring
39	900668	1	Muffler Cover	90	901052	1	Spring Cover
* 40	900609	1	Muffler	91	901016	1	Constant Force Spring
41	900664	1	Reed Valve	92	901017	1	Spool, Spring
42	900665	1	Reed Plate	93	900748	1	Washer
43	901089	1	Exhaust Baffle	* 94	900735	1	Screw
* 44	900616	1	O-Ring	95	903702	1	Handle Left Side
45	901059	1	Front Channel	96	900703	1	Handle Bracket
46	900598	2	Screw 10-32 x 5/16" (red)	97	900755	1	Bushing Actuator
47	902402	1	Label, Li-Ion + Fuel	98	900788	1	Actuator Assembly
** 48	916003	1	Label, Warning	99	404433	1	Pin Actuator
49	404385	1	Light Pipe	100	901041	1	Wear Strip
50	903701	1	Handle Right Side	101	901062	1	Screw 6-32 x 1/8"
51	900754	2	Screw 8-32 x 1/2" (yellow)	102	901066	4	Screw- Plastite
				* 103	901021	1	Piston Bumper

- * Denotes Normal Wear Items
- Apply Loctite RC-620 (Green) Part No.401491
- ** Make sure Warning Label (916003) is properly affixed replace if necessary.
Label is available at no charge through the Service Dept.
- Denotes Change

SAFETY INSTRUCTIONS

WEAR EYE AND HEARING PROTECTION



Always wear hearing protection and eye protection devices, including side shields when operating or working in the vicinity of a tool.



IM200Li 18 Ga. Cordless Brad Nailer 903700

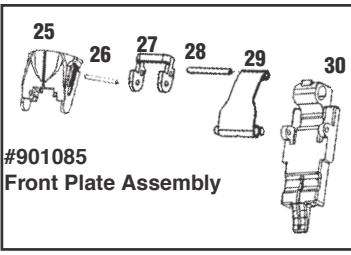
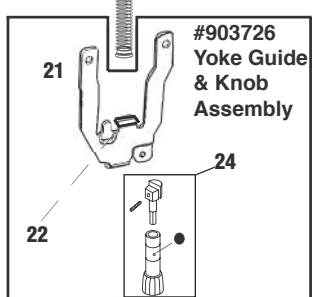
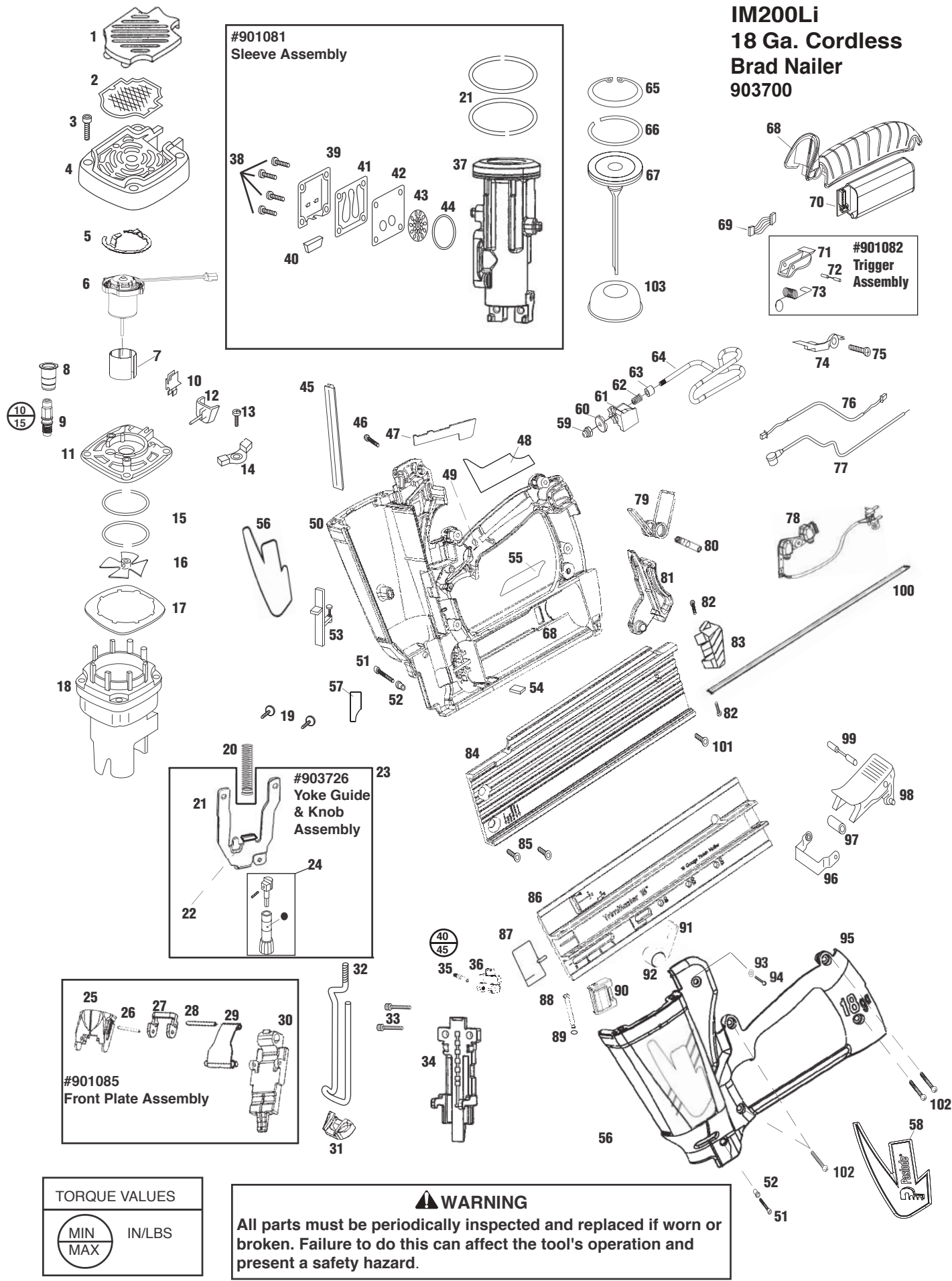
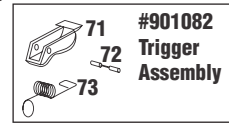
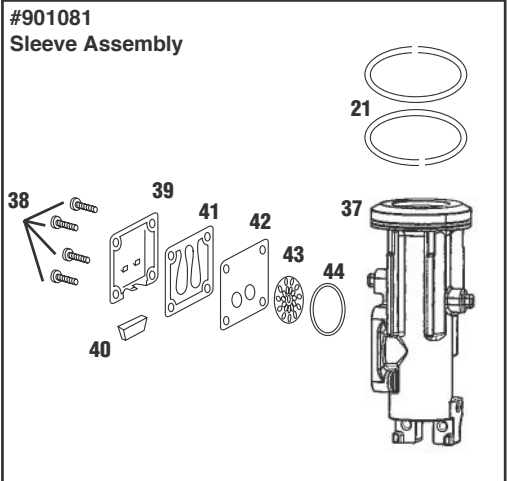

TORQUE VALUES	
MIN	IN/LBS
MAX	

⚠ WARNING
All parts must be periodically inspected and replaced if worn or broken. Failure to do this can affect the tool's operation and present a safety hazard.

ACCESSORIES

Carrying Case

Part No. 902445

Battery



Part No. 902654

Paslode Cordless Lubricating Oil



Part No. 401482

Torx Key - T7

For tightening fan blade to motor

Part No. 900183

Battery Charger

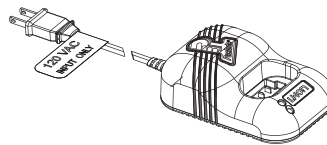

Part No. 902667

Clear Safety Glasses



Part No. 401382

Tool Cleaner

Ideal cleaner for all Paslode tools



Part No. 219348

No- Mar Tip - Hard Tip

Part No. 901048

No- Mar Tip - Soft Tip

Part No. 901067



An Illinois Tool Works Co.
120 Travail Rd.
Markham, Ontario
L3S 3J1

www.paslode.com