

Tool Schematic and Parts - Cordless Framing Nailer

Paslode[®]

Model CF325Li
Part No. 902600

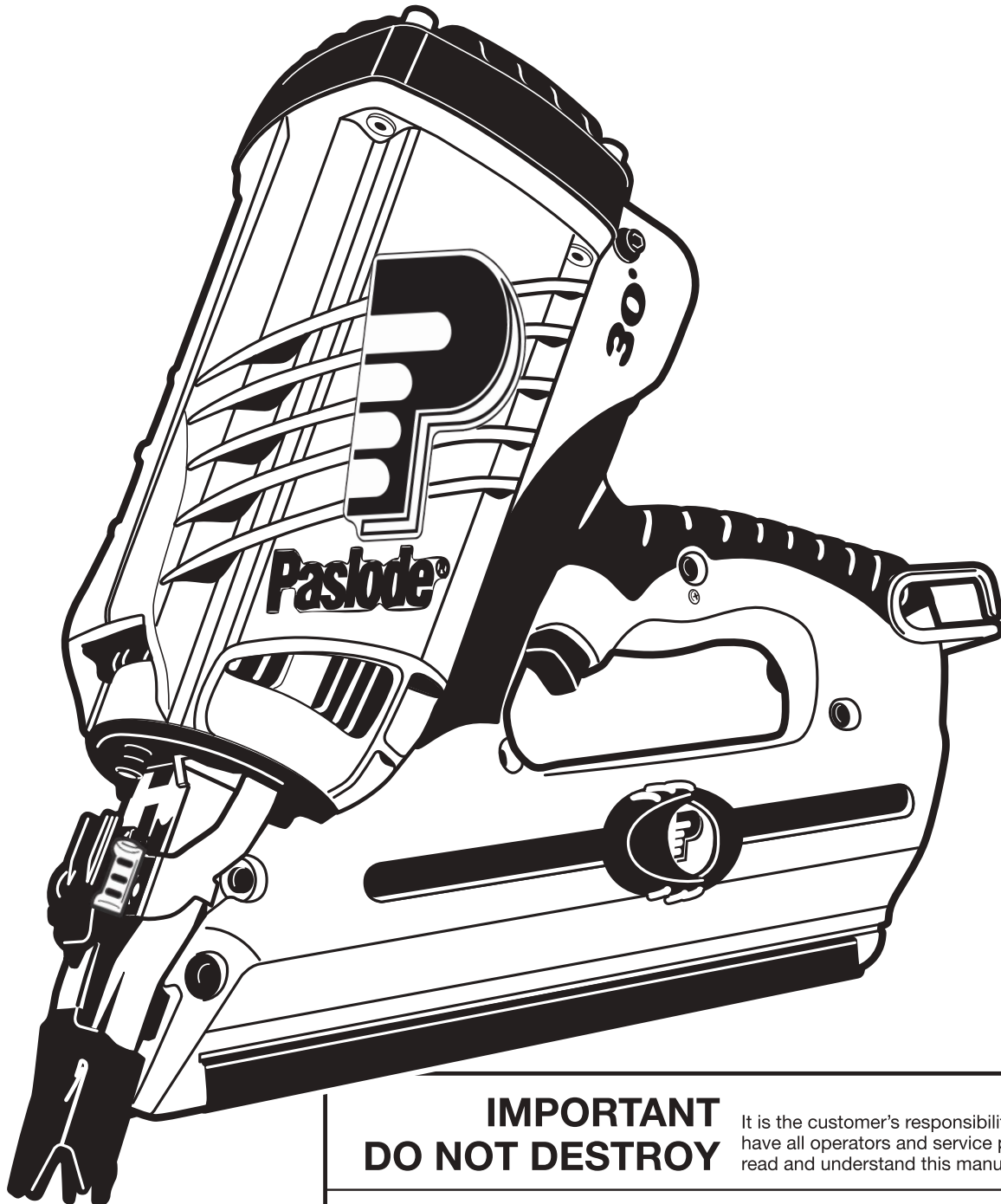

**IMPORTANT
DO NOT DESTROY**

It is the customer's responsibility to have all operators and service personnel read and understand this manual.

Printed in U.S.A. ©2013 Illinois Tool Works Inc.

PARTS LEGEND PASLODE CORDLESS FRAMING NAILER, 902600

1	902207	1	Grille	49	404419	1	Bumper
2	900315	1	Filter	50	902239	1	Spring
3	900902	3	Screw, Thread Forming Sems 8-32 x 5/8	51	900934	2	Steel Ring, Sleeve
4	901422	1	PC Board	52	901204	1	Sleeve Assembly, includes rings
5	901430	1	Fan Motor Assembly (Includes motor mount)	53	404464	2	Rubber Stop
6	900468	1	Washer, Motor Shaft	54	404424	1	Reed Valve
7	901063	4	Shoulder Screw 10-24 x 1-1/2	55	404422	1	Muffler
8	904517	1	Fuel Barb	56	404423	1	Muffler Cover
9	401356	1	Motor Sleeve	57	902227	1	Utility Hook Button
10	900286	1	Spark Plug Assembly, includes O-Ring	58	900596	3	Screw Thread Forming Sems 8-32 x 7/16
11	902215	1	Fuel Tube	59	403816	2	Socket Head Capscrew 10-24 x 1-1/8
12	404453	1	Bracket, Cylinder Head	60	404445	2	Bushing, Shear Block
13	902210	1	Fuel Dosing Lever	61	902223	1	Wear Plate, Nose
14	902209	1	Fuel Door	62	901249	1	Upper Probe
15	902230	1	Pin, Fuel Door	63	902225	1	Lower Probe
16	902235	1	Retaining Ring, Fuel Door	64	900592	2	S.H.C.S. Sems 10-32 x 1/2
17	902221	1	Cylinder Head	65	401380	1	Tie Bar
18	900935	2	Seal Ring	66	902211	1	Fuel Pivot Arm
19	403167	1	Fan Blade Assembly	67	902602	1	Housing Assembly
20	902604	1	Spark Unit Assembly	68	902237	1	Utility Hook
21	902625	1	Molded Circuit Assembly	69	902603	2	Label, "P"
22	900478	1	Spark Plug Assembly Wire	70	902605	2	Label, Paslode®
23	900231	1	Clip, Wire Spark Plug	71	902240	1	Retainer Ring, Sleeve
■ 24	403987	2	Screw Thread Forming 6-32 x 1/4	▲ 72	900593	3	S.H.C.S. Sems 10-24 x 5/8
25	902606	1	Handle Assembly Kit - Right & Left	73	403985	1	Follower
26	404448	1	Roller Lever Assembly	74	901415	1	Follower Bushing Spring Assembly
27	404702	2	Screw Thread Forming 6 x 3/8	75	901202	1	Retaining Ring
28	404436	1	Nail Channel	76	403986	1	Spring Pin
29	902623	1	Cover Plate Magazine	77	902204	1	Follower Guide
30	901222	2	Shoulder Screw 10-32 x 1/2	78	902205	1	Follower Button
31	902206	1	Cap	79	404457	1	Spring
32	404412	1	Wear Plate, Chamber Lock	80	904571	2	Foam Pad
33	900453	4	Screw Plastite 8-16 x 7/8	81	902619	1	Probe Release
** 34	902608	1	Warning Label	82	902620	2	Button, Probe Release
35	902220	1	Magazine Channel	83	404426	1	Exhaust Baffle
■ 36	900594	4	S.H.C.S. Sems 8 - 32 x 1/2	84	404425	1	Reed Plate
37	901241	1	Stop, Cage	■ 85	900969	4	Torx Screw 8-32 x 5/8
38	404451	1	Lockout Bar, Follower	86	900481	1	O-Ring
39	902219	1	Shear Block	87	902222	1	Combustion Chamber Ring
40	901238	1	Spring, Flat	88	404407	1	Combustion Chamber
41	404435	1	Trigger	89	900595	2	Torx Screw Sems 8-32 x 3/8
42	900269	1	Chamber Lock Bar	90	902212	1	Fuel Block
43	404927	1	Spring, Trigger	91	902624	1	Nameplate
44	401328	1	Retainer ring	92	900427	1	Light Pipe
45	401461	2	Piston Ring	93	902607	1	Li-ion Fuel Label
46	404485	1	Piston Assembly, includes rings	94	404411	2	Spring
47	902233	1	Combustion Chamber Assembly	95	900546	1	Brass Insert
48	404827	2	Pin	96	900597	1	Screw Thread Forming Sems 6-19 x 3/8
				97	902238	1	Utility Hook Spring
				98	902213	1	Pin Fuel Arm Pivot

** Make sure Warning Label (#902608) is properly affixed.
Replace if necessary. Label is available at no charge through the Service Department.

- ▲ Apply Loctite 242 (Blue) Part No. 093500.
- Apply Loctite RC-620 (Green) Part No. 401491
- Denotes new change.

SAFETY INSTRUCTIONS

WEAR EYE AND HEARING PROTECTION



Always wear hearing protection and eye protection devices, including side shields when operating or working in the vicinity of a tool.



⚠ WARNING

All parts must be periodically inspected and replaced if worn or broken. Failure to do this can affect the tool's operation and present a safety hazard.

**Model CF325Li
#902600**

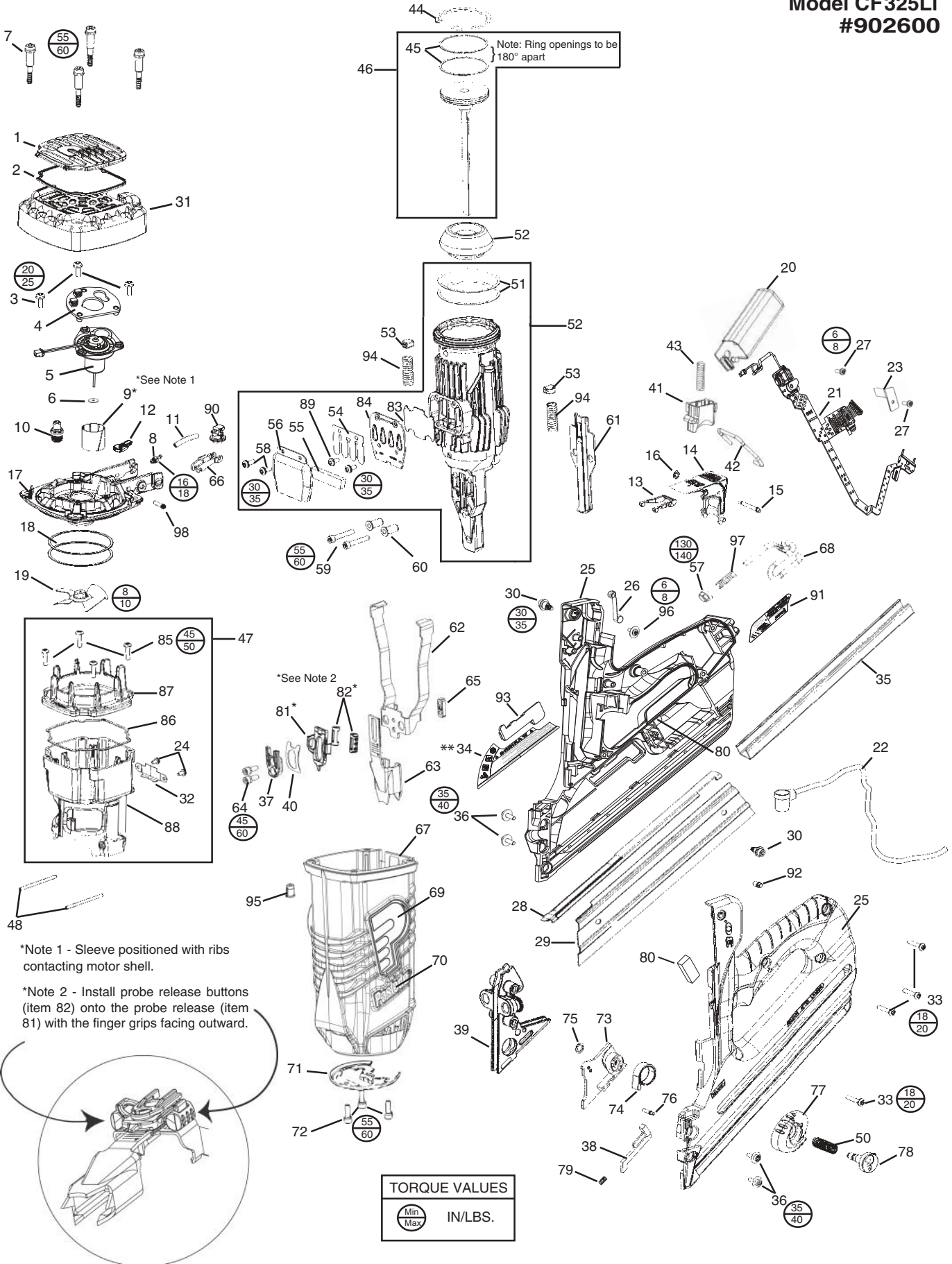

*Note 1 - Sleeve positioned with ribs contacting motor shell.

*Note 2 - Install probe release buttons (item 82) onto the probe release (item 81) with the finger grips facing outward.

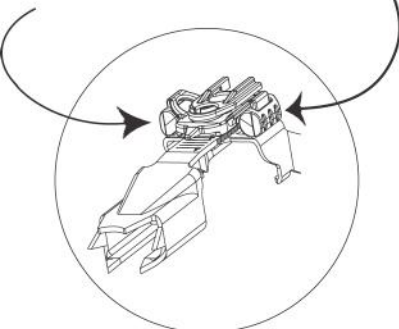

ACCESSORIES

Battery Cell



Part No. 902654

Battery Charger

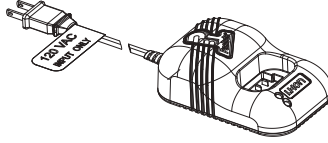

Part No. 902667

Paslode Cordless Lubricating Oil

Specially formulated for use in Paslode® Cordless tools.



Part No. 401482

5/32" Hex Key

For clearing jams and servicing.



Part No. 401331

No-Mar Work Contacting Element

Rubber tipped WCE to eliminate marring work surface.



Part No. 901252

Paslode Cordless Nailer Case



Part No. 902609

Clear Safety Glasses



Part No. 401382

Cordless Tool Cleaner

Ideal cleaner for all Paslode®



Part No. 219348

For technical support call 1-800-222-6990.

For factory direct Paslode replacement parts and
service go to:

www.paslode.com/partsandservice.html



An Illinois Tool Works Company
888 Forest Edge Drive
Vernon Hills, Illinois 60061