

ELECTRIC TOOL PARTS LIST

■ SLIDE COMPOUND SAW
Model C 8FB2

1995 • 5 • 18
(E2)

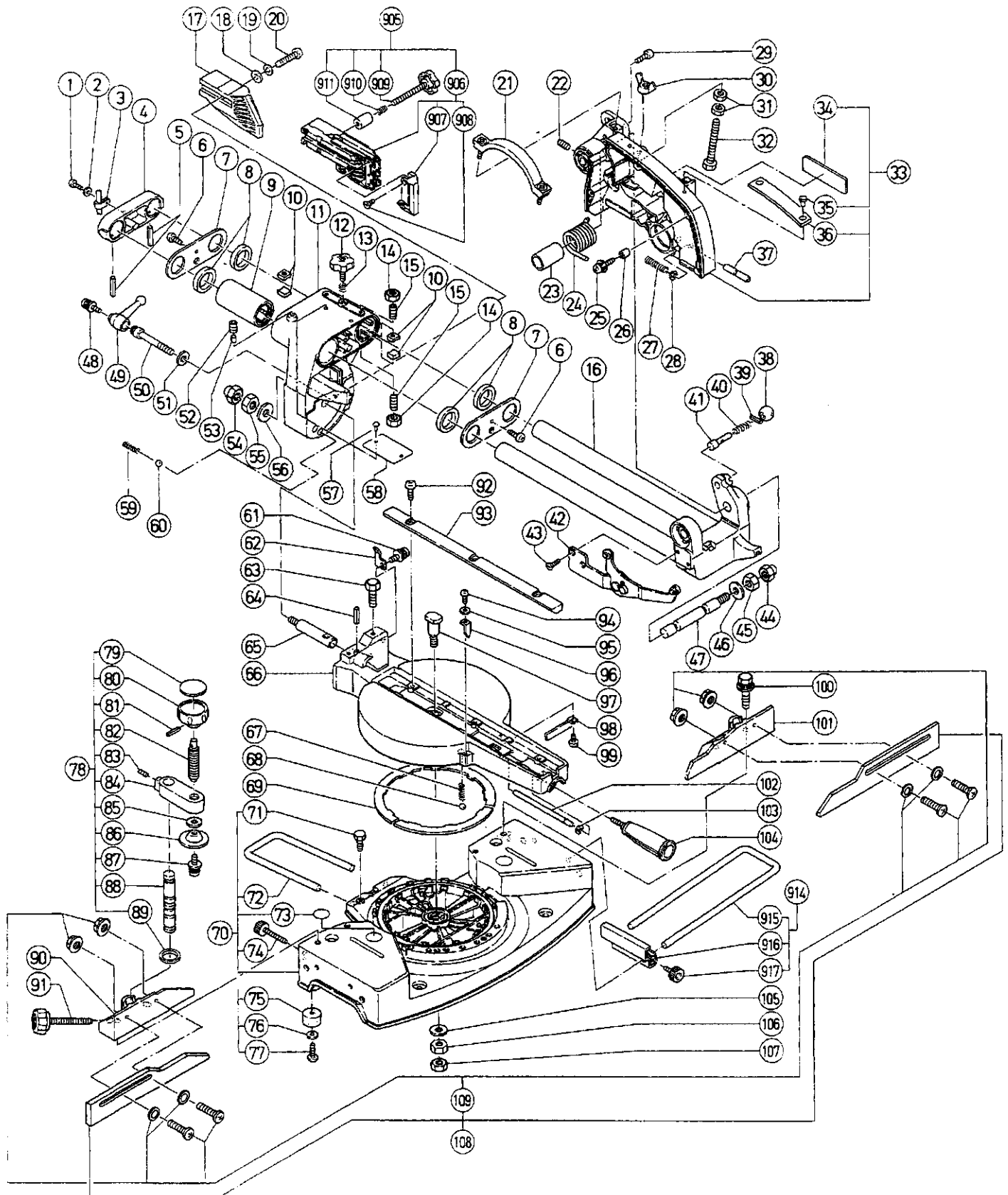

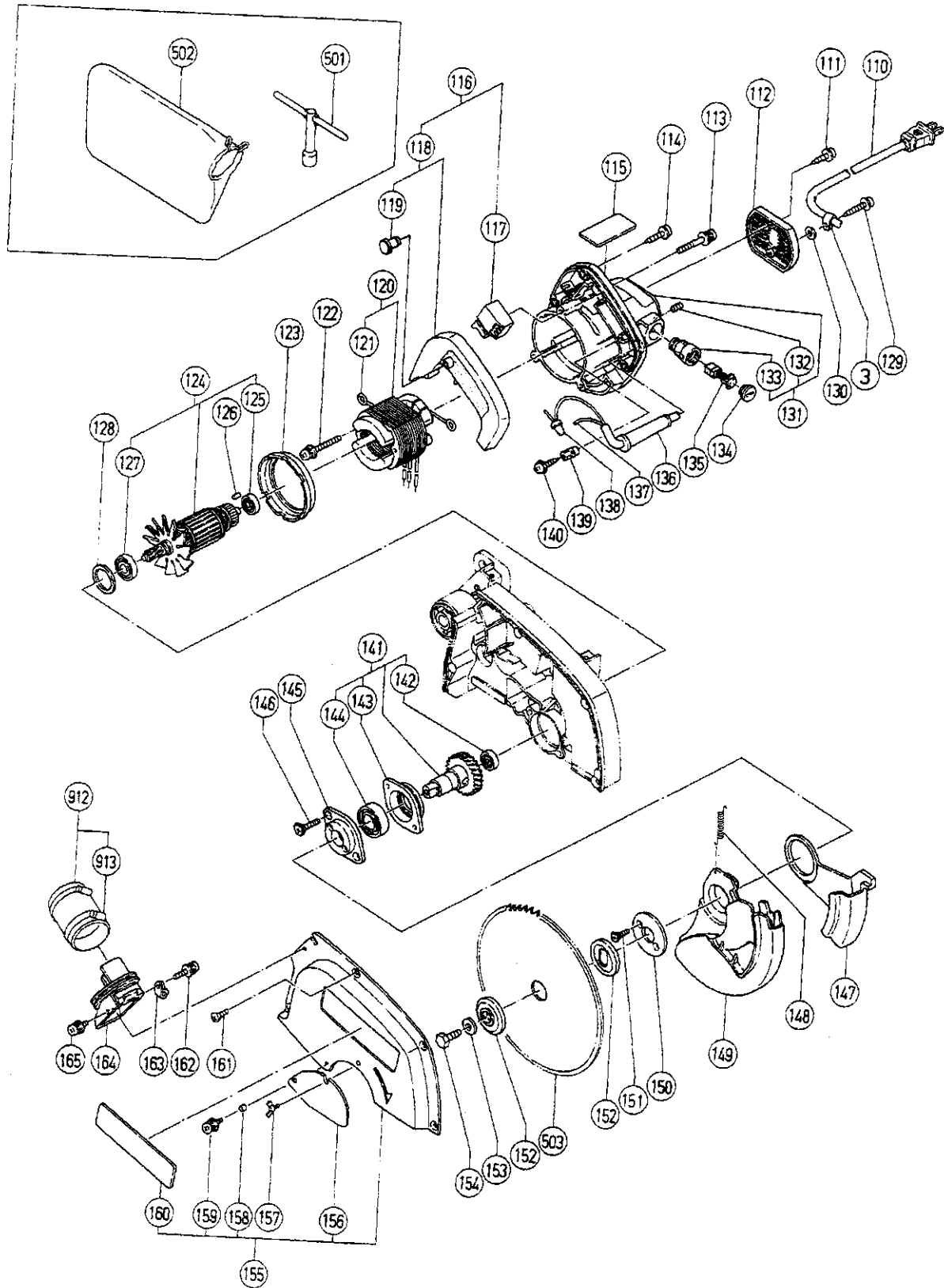

PARTS

C 8FB2

ITEM NO.	CODE NO.	DESCRIPTION	NO. USED	REMARKS
1	949-219	MACHINE SCREW M4X16 (10 PCS.)	1	
2	949-429	BOLT WASHER M4 (10 PCS.)	1	
3	948-193	NYLON CLIP	2	
4	307-222	SUPPORT	1	
5	949-688	ROLL PIN D6X40 (10 PCS.)	2	
6	949-237	MACHINE SCREW M5X12 (10 PCS.)	2	
7	998-227	PACKING COVER	2	
8	998-228	FELT	4	
9	998-825	BALL BUSHING	1	
10	998-223	BUSHING	4	
11	307-228	HOLDER (A)	1	
12	998-225	KNOB BOLT M8X20	1	
13	998-224	LOCK SPRING	1	
14	949-588	LOCK NUT M8 (10 PCS.)	4	
15	974-500	HEX. SOCKET SET SCREW M8X18	4	
16	307-225	HINGE	1	
17	998-853	GUARD	1	
18	949-433	BOLT WASHER M8 (10 PCS.)	1	
19	949-457	SPRING WASHER M8 (10 PCS.)	1	
20	949-273	MACHINE SCREW M8X30 (10 PCS.)	1	
21	998-855	HANDLE	1	
22	986-481	HEX. SOCKET SET SCREW M6X18	2	
23	310-653	SLEEVE	1	
24	998-234	SPRING	1	
25	995-098	MACHINE SCREW (W/WASHERS) M5X20	1	
26	975-637	COLLAR (B)	1	
27	998-852	SPRING	1	
28	974-577	RETAINING RING (E - TYPE) FOR D7 SHAFT	1	
29	949-819	HEX. SOCKET HD. BOLT M5X10 (10 PCS.)	1	
30	949-312	WING NUT M8 (10 PCS.)	1	
31	949-558	NUT M8 (10 PCS.)	2	
32	952-013	BOLT M8X100	1	
33	310-658	GEAR CASE ASS'Y	1	INCLUD.25,26,34 - 36
34	310-655	WARNING LABEL	1	
35	949-510	RIVET D2.5X4.8 (10 PCS.)	2	
36	307-788	CAUTION PLATE (E)	1	
37	974-578	STOPPER PIN	1	
38	967-896	GRIP	1	
39	949-539	ROLL PIN D3X25 (10 PCS.)	1	
40	948-383	GAUGE SPRING	1	
41	988-874	SET PIN	1	
42	307-855	LINK	1	
43	949-340	FLAT HD. SCREW M8X18 (10 PCS.)	2	
44	998-821	CAP NUT M12	1	
45	949-581	NUT M12 (10 PCS.)	1	
46	949-437	BOLT WASHER M12 (10 PCS.)	1	
47	998-235	HINGE SHAFT	1	
48	307-232	MACHINE SCREW (W/WASHERS) M8X12 (BLACK)	1	
49	998-219	CLAMP LEVER	1	
50	998-218	BOLT (LEFT HAND) M10	1	
51	302-998	WASHER (I)	1	

*: ALTERNATIVE PARTS

PARTS

C 8FB2

ITEM NO.	CODE NO.	DESCRIPTION	NO. USED	REMARKS
52	986-458	HEX. SOCKET SET SCREW M8X8	1	
53	976-301	BEARING LOCK	1	
54	998-821	CAP NUT M12	1	
55	949-561	NUT M12 (10 PCS.)	1	
56	949-437	BOLT WASHER M12 (10 PCS.)	1	
57	949-509	RIVET D2.5X3.2 (10 PCS.)	2	
58	998-999	CAUTION PLATE (A)	1	
59	967-150	SPRING (C)	2	
60	959-153	STEEL BALL D12.7 (10 PCS.)	2	
61	997-314	MACHINE SCREW (W/WASHERS) M6X10	1	
62	996-220	INDICATOR	1	
63	303-409	NYLOCK BOLT M8X25	2	
64	998-820	SLOTTED PIN D8X30	1	
65	998-819	HOLDER SHAFT	1	
66	998-812	TURN TABLE	1	
67	967-150	SPRING (C)	1	
68	959-153	STEEL BALL D12.7 (10 PCS.)	1	
69	998-811	LINER	3	
70	308-797	BASE ASS'Y	1	INCLUD.71 -- 77
71	949-613	BOLT M6X18 (10 PCS.)	1	
72	998-844	HOLDER	1	
73		CAUTION LABEL (J)	2	
74	998-843	KNOB BOLT M8X52	2	
75	964-851	BASE RUBBER	5	
76	949-431	BOLT WASHER M5 (10 PCS.)	5	
77	949-241	MACHINE SCREW M5X20 (10 PCS.)	5	
78	307-559	WISE AND KNOB ASS'Y	1	INCLUD.79 -- 89,91
79	998-832	LABEL (A)	1	
80	998-283	KNOB	1	
81	949-548	ROLL PIN D4X25 (10 PCS.)	1	
82	998-830	SCREW	1	
83	996-281	HEX. SOCKET SET SCREW M8X16	1	
84	301-850	SCREW HOLDER	1	
85	949-434	BOLT WASHER M10 (10 PCS.)	1	
86	996-281	WISE PLATE	1	
87	997-314	MACHINE SCREW (W/WASHERS) M6X10	1	
88	307-230	WISE SHAFT	1	TILL 11.1992
89	976-442	COLLAR (A) FOR D25.4 HOLE	1	
90	307-220	FENCE (B)	1	
91	998-833	KNOB BOLT M10X70	1	
92	949-258	MACHINE SCREW M6X20 (10 PCS.)	6	
93	998-818	TABLE INSERT	2	
94	949-215	MACHINE SCREW M4X8 (10 PCS.)	1	
95	949-429	BOLT WASHER M4 (10 PCS.)	1	
96	977-587	INDICATOR	1	
97	998-813	SHAFT	1	
98	998-814	SPACER	1	
99	949-216	MACHINE SCREW M4X10 (10 PCS.)	1	
100	307-221	BOLT (W/WASHERS) M8X35 (BLACK)	4	
101	307-219	FENCE (A)	1	
102	998-815	SHAFT	1	

*: ALTERNATIVE PARTS

PARTS

C 8FB2

ITEM NO.	CODE NO.	DESCRIPTION	NO. USED	REMARKS
103	974-577	RETAINING RING (E - TYPE) FOR D7 SHAFT	1	
104	978-805	SIDE HANDLE	1	
105	967-115	WASHER (T)	1	
106	949-561	NUT M12 (10 PCS.)	1	
107	949-574	LOCK NUT M12 (10 PCS.)	1	
108	310-657	SLIDE FENCE ASS'Y	1	INCLUD.109
109	310-658	SCREW	1	
110	310-646	CORD	1	
111	302-066	TAPPING SCREW (W/FLANGE) D4X20 (BLACK)	1	
112	998-254	TAIL COVER	1	
113	997-841	MACHINE SCREW (W/WASHERS) M5X50 (BLACK)	3	
114	304-035	TAPPING SCREW (W/FLANGE) D4X25 (BLACK)	3	
115		NAME PLATE	1	
116	998-986	SWITCH AND HANDLE COVER SET	1	INCLUD.117,118
117	998-839	SWITCH (1P PILLAR TYPE) W/LOCK	1	
118	998-985	HANDLE COVER ASS'Y	1	INCLUD.119
119	951-895	LOCK OFF BUTTON	1	
120	340-108G	STATOR ASS'Y (B) 115V	1	INCLUD.121
121	975-884	BRUSH TERMINAL	2	
122	307-224	MACHINE SCREW (W/WASHERS) M5X60 (BLACK)	2	
123	998-253	FAN GUIDE (B)	1	
124	360-072U	ARMATURE ASS'Y 115V	1	INCLUD.125,127
125	808-VVM	BALL BEARING 808VVMC2EPS2L	1	
126	976-301	BEARING LOCK	1	
127	800-1VV	BALL BEARING 8001VVCMP2L	1	
128	996-252	RUBBER RING	1	
129	304-035	TAPPING SCREW (W/FLANGE) D4X25 (BLACK)	1	
130	978-448	WASHER (B)	1	
131	996-269	HOUSING ASS'Y	1	INCLUD.132,133
132	996-426	HEX. SOCKET SET SCREW M5X6	2	
133	996-270	BRUSH HOLDER	2	
134	996-259	BRUSH CAP	2	
135	999-043	CARBON BRUSH (1 PAIR)	2	
136	994-565	CORD ARMOR D 10.1	1	
137	988-894	TUBE (D)	1	
138	959-140	CONNECTOR 50091 (10 PCS.)	1	
139	937-631	CORD CLIP	1	
140	995-062	TAPPING SCREW (W/WASHER) D4X16	2	
141	310-645	SPINDLE ASS'Y	1	INCLUD.142 - 144
142	808-VVM	BALL BEARING 808VVMC2EPS2L	1	
143	996-238	BEARING HOLDER	1	
144	800-4VV	BALL BEARING 8004VVCMP2S	1	
145	310-644	COVER HOLDER	1	
146	996-240	FLAT HD.SCREW (W/TOOTHED LOCK WASH)M5X35	2	
147	303-744	SUB COVER	1	
148	303-745	RETURN SPRING	1	
149	307-654	SAFETY COVER	1	
150	310-651	COVER	1	
151	996-244	FLAT HD. SCREW(W/TOOTHED LOCK WASH)M4X12	2	
152	998-836	WASHER (C)	2	
153	996-257	WASHER	1	

*: ALTERNATIVE PARTS

PARTS

C 8FB2

ITEM NO.	CODE NO.	DESCRIPTION	NO. USED	REMARKS
154	996-258	BOLT (LEFT HAND) M7X17.5	1	
155	310-648	SAW COVER ASS'Y	1	INCLUD.156,158 - 160
158	310-649	SPINDLE COVER	1	
157	949-397	WING BOLT M5X10 (10 PCS.)	1	
158	998-980	SPACER	1	
159	996-274	MACHINE SCREW (W/WASHERS) M5X8	1	
160	998-842	HITACHI LABEL	1	
161	996-249	PAN HD. SCREW M5X10	4	
162	990-541	MACHINE SCREW (W/WASHERS) M5X16	1	
163	996-530	NYLON CLIP	1	
164	996-250	DUCT	1	
165	996-274	MACHINE SCREW (W/WASHERS) M5X8	1	

STANDARD ACCESSORIES

ITEM NO.	CODE NO.	DESCRIPTION	NO. USED	REMARKS
501	998-658	BOX WRENCH 10MM	1	
502	998-845	DUST BAG	1	
503	998-840	TCT SAW BLADE 216MM -- D15.88 HOLE -- NT24	1	

OPTIONAL ACCESSORIES

ITEM NO.	CODE NO.	DESCRIPTION	NO. USED	REMARKS
901	998-865	SAW BLADE (COMBINATION) 216MM -- D15.88HOLE	1	
902	998-860	TCT SAW BLADE 216MM -- D15.88 HOLE -- NT36	1	
903	998-862	TCT SAW BLADE 216MM -- D15.88 HOLE -- NT60	1	
904	998-864	TCT SAW BLADE 216MM -- D15.88 HOLE -- NT80	1	
905	998-984	GUARD ASS'Y (A)	1	INCLUD.906 - 911
906	998-847	GUARD ASS'Y	1	INCLUD.907,908
907	998-849	GUARD (C)	1	
908	998-850	FLAT HD. SCREW (BRASS) M4X6	4	
909	998-848	KNOB BOLT M8X75	1	
910	873-923	GOVERNOR SPRING	1	
911	998-823	SLEEVE	1	
912	998-857	DUCT HOSE ADAPTER ASS'Y	1	INCLUD.913
913	973-176	HOSE BAND	2	
914	998-866	GUIDE ASS'Y	1	INCLUD.74,915 - 917
915	998-834	HOLDER	2	
916	998-835	STOPPER	1	
917	998-836	KNOB BOLT M6X11	1	

*: ALTERNATIVE PARTS