

ELECTRIC TOOL PARTS LIST

■ SLIDE COMPOUND MITER SAW
Model C 12RSH

2015 • 12 • 22
(E2a)

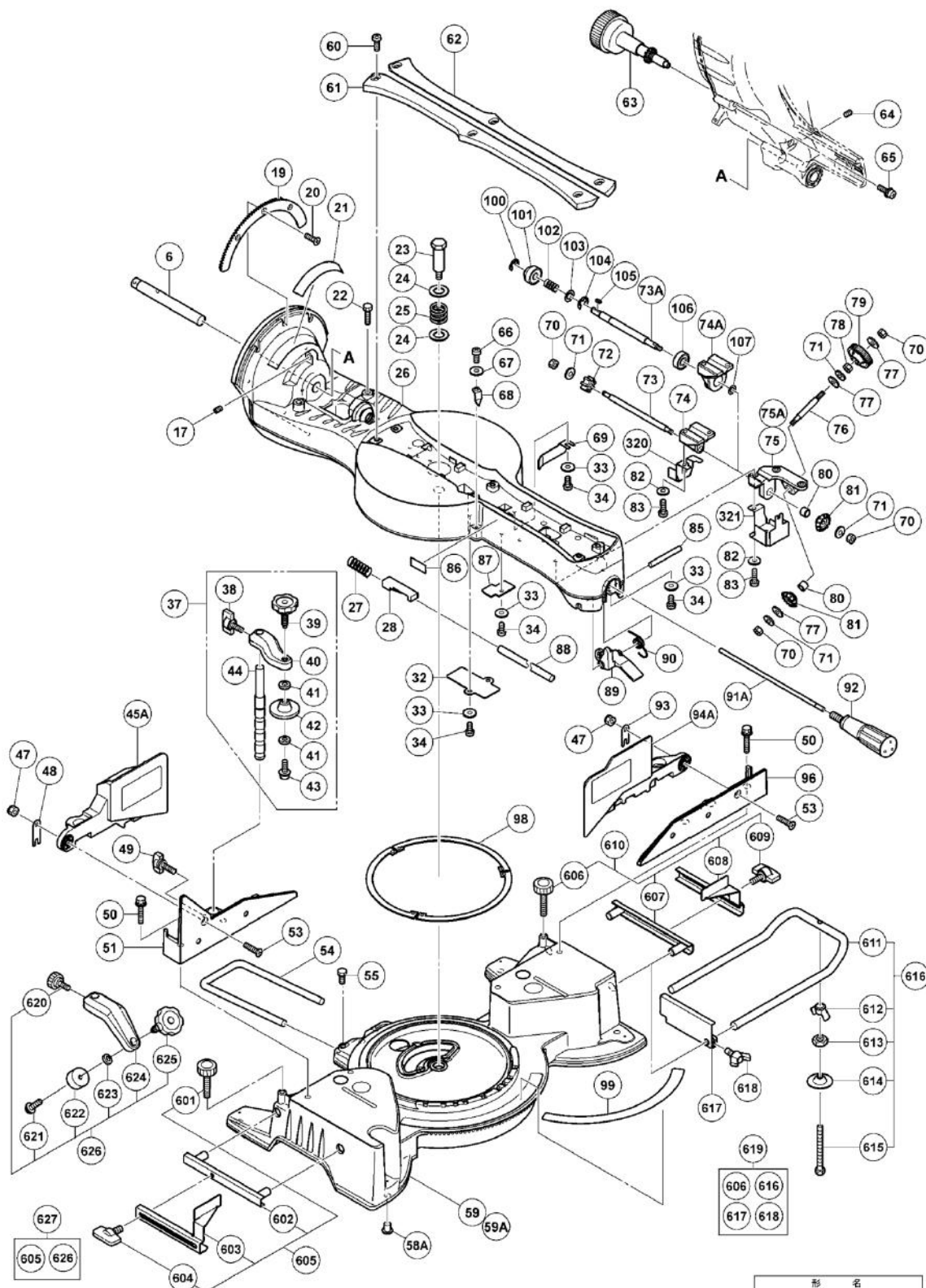

Rev.6

形名
C12RSH(1/3)

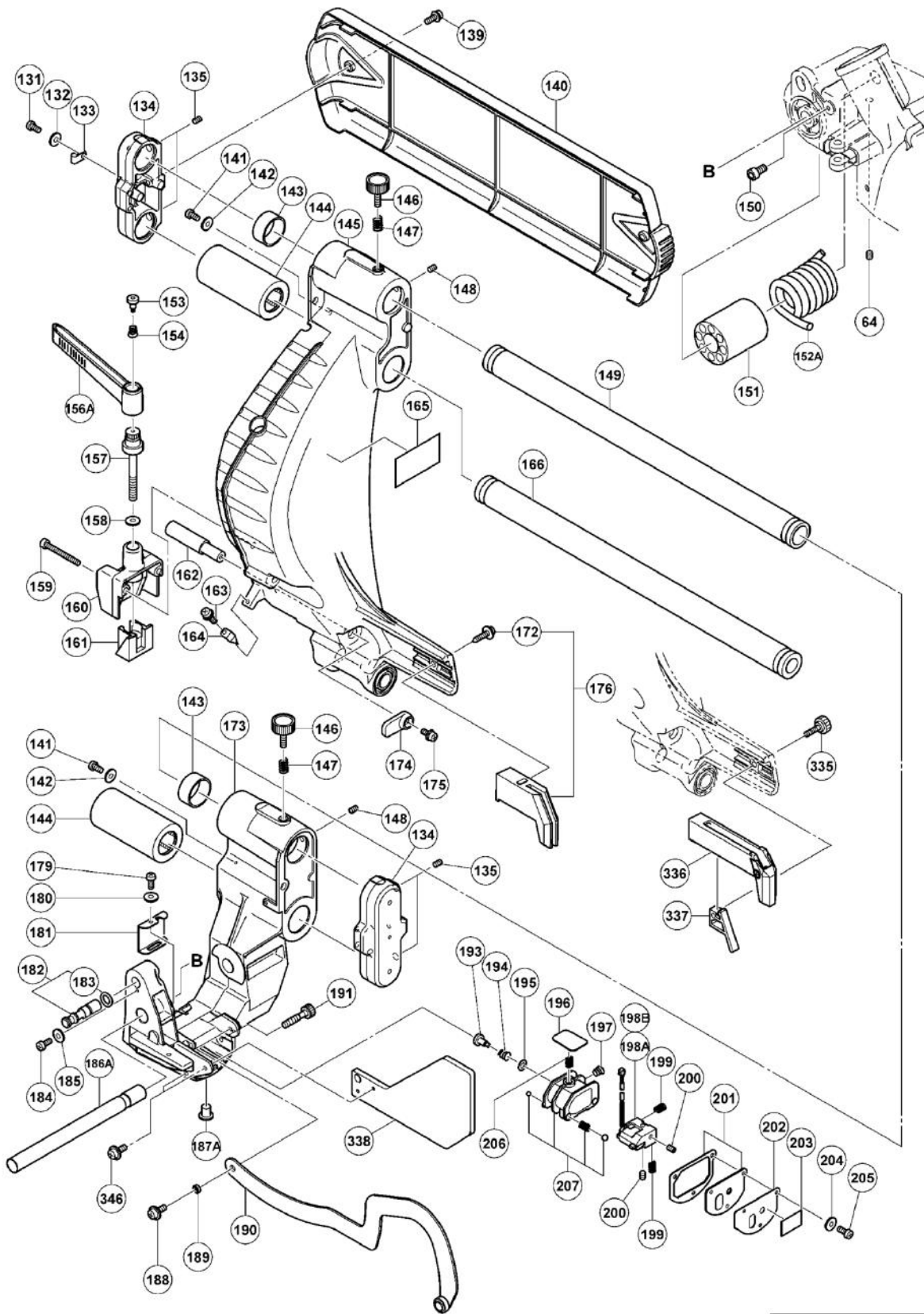

Rev.6

形名
C12RSH(2/3)

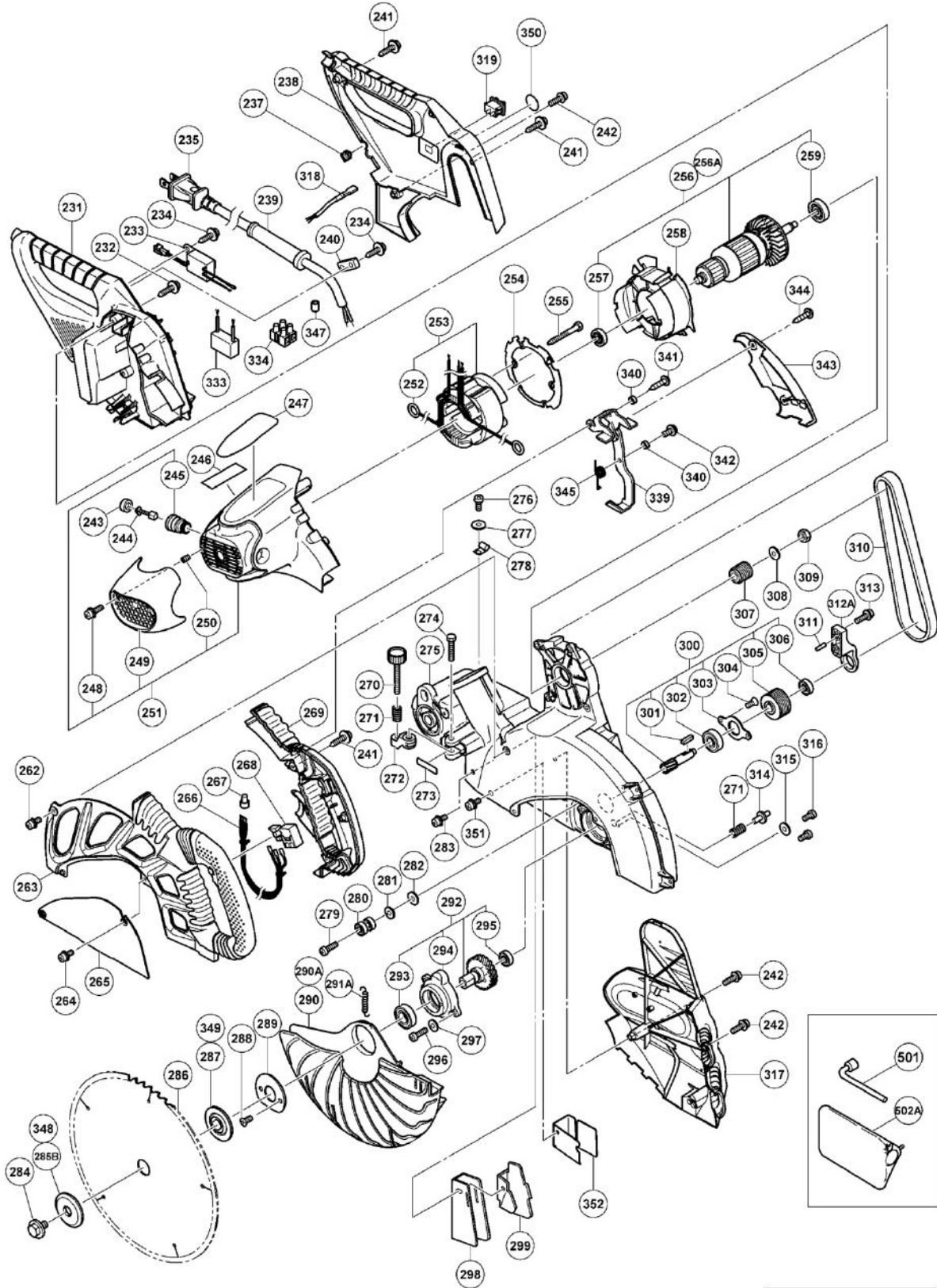

Rev.5

形名
C12RSH(3/3)

PARTS

C12RSH

ITEM NO.	CODE NO.	DESCRIPTION	NO. USED	REMARKS
6	324391	HOLDER SHAFT	1	
17	324612	NYLOCK HEX. SOCKET SET SCREW M8X16	1	
19	324399	GEAR (A)	1	
20	949325	FLAT HD. SCREW M4X16 (10 PCS.)	3	
21	324416	SCALE (B)	1	
22	303409	NYLOCK BOLT M8X25	2	
23	324401	SHAFT (B)	1	
24	955818	BOLT WASHER M16	2	
25	324402	SPRING (B)	1	
26	324394	TURN TABLE	1	
27	321417	SPRING (E)	1	
28	322280	STOPPER (A)	1	
32	321336	PIN COVER	1	
33	949429	BOLT WASHER M4 (10 PCS.)	4	
34	949215	MACHINE SCREW M4X8 (10 PCS.)	4	
37	324378	WISE ASS'Y	1	INCLUD.38-44
38	307947	WING BOLT M6X12	1	
39	308396	KNOB BOLT M10	1	
40		SCREW HOLDER	1	
41	996722	WASHER	2	
42	322047	WISE PLATE	1	
43	996247	MACHINE SCREW (W/WASHERS) M5X12 (BLACK)	1	
44	324380	WISE SHAFT	1	
45A	324454	SUB FENCE (B)	1	
47	311144	NYLON NUT M6	2	
48	324377	PLATE (B)	1	
49	302459	WING BOLT M6X17	1	
50	307221	BOLT (W/WASHERS) M8X35 (BLACK)	4	
51	324385	FENCE (B)	1	
53	949342	FLAT HD. SCREW M6X25 (10 PCS.)	2	
54	998834	HOLDER	1	
55	949610	BOLT M6X10 (10 PCS.)	1	
58A	323606	BASE RUBBER	4	
59	324456	BASE ASS'Y	1	INCLUD.58.99 (TILL 7.2013 FOR USA.CAN)
59A	336253	BASE ASS'Y	1	INCLUD.58.99 SINCE 8.2013 FOR USA.CAN
60	302317	MACHINE SCREW M5X16 (BLACK)	6	
61	324411	TABLE INSERT (B)	1	
62	324410	TABLE INSERT (A)	1	
63	324370	KNOB (B)	1	
64	307956	SEAL LOCK HEX. SOCKET SET SCREW M6X10	2	
65	307294	MACHINE SCREW (W/WASHERS) M5X16 (BLACK)	1	
66	949217	MACHINE SCREW M4X12 (10 PCS.)	1	
67	949429	BOLT WASHER M4 (10 PCS.)	1	
68	321329	INDICATOR	1	
69	321342	SPACER (A)	1	
70	949567	LOCK NUT M6 (10 PCS.)	4	
71	949455	SPRING WASHER M6 (10 PCS.)	4	
72	324407	GEAR (D)	1	TILL 7.2013 FOR USA.CAN
73	324405	BEVEL SHAFT (B)	1	TILL 7.2013 FOR USA.CAN
73A	336255	BEVEL SHAFT (C)	1	SINCE 8.2013 FOR USA.CAN
74	324404	SHAFT HOLDER (B)	1	TILL 7.2013 FOR USA.CAN
74A	336257	SHAFT HOLDER (B)	1	SINCE 8.2013 FOR USA.CAN
75	324403	SHAFT HOLDER (A)	1	TILL 7.2013 FOR USA.CAN
75A	336258	SHAFT HOLDER (A)	1	SINCE 8.2013 FOR USA.CAN
76	324408	BEVEL SHAFT (A)	1	
77	949432	BOLT WASHER M6 (10 PCS.)	3	
78	949556	NUT M6 (10 PCS.)	1	
79	324409	KNOB (A)	1	
80	950817	METAL D8X10	2	
81	324406	BEVEL GEAR	2	

Parts

C12RSH

ITEM NO.	CODE NO.	DESCRIPTION	NO. USED	REMARKS
82	949454	SPRING WASHER M5 (10 PCS.)	4	
83	949241	MACHINE SCREW M5X20 (10 PCS.)	4	
85	321339	LEVER SHAFT	1	
86		CAUTION LABEL (C)	1	FOR USA.CAN
87	324395	COVER (B)	1	
88	324396	SHAFT (C) D6	1	
89	321338	LEVER	1	
90	321340	SPRING (D)	1	
91A	334378	SHAFT (A)	1	
92	322283	SIDE HANDLE	1	
93	324381	PLATE (A)	1	
94A	324455	SUB FENCE (A)	1	
96	324384	FENCE (A)	1	
98	324400	LINER	3	
99	315210	SCALE (A)	1	
100	673489	RETAINING RING (E-TYPE) FOR D5 SHAFT	1	SINCE 8.2013 FOR USA.CAN
101	336256	ROLLER	1	SINCE 8.2013 FOR USA.CAN
102	336254	SPRING (A)	1	SINCE 8.2013 FOR USA.CAN
103	949445	WASHER M10 (10 PCS.)	1	SINCE 8.2013 FOR USA.CAN
104	942827	RETAINING RING (E-TYPE) FOR D8 SHAFT	1	SINCE 8.2013 FOR USA.CAN
105	944109	FEATHER KEY 3X3X8	1	SINCE 8.2013 FOR USA.CAN
106	6000DD	BALL BEARING 6000DDCMPS2L	1	SINCE 8.2013 FOR USA.CAN
107	949426	WASHER M8 (10 PCS.)	1	SINCE 8.2013 FOR USA.CAN
131	949217	MACHINE SCREW M4X12 (10 PCS.)	1	
132	949429	BOLT WASHER M4 (10 PCS.)	1	
*133	948614	NYLON CLIP	1	
*133	948193	NYLON CLIP	1	FOR USA.CAN
*133	967579	NYLON CLIP	1	FOR TPE
134	324417	SUPPORT	2	
135	961554	HEX. SOCKET SET SCREW M8X10	4	
139	307294	MACHINE SCREW (W/WASHERS) M5X16 (BLACK)	2	
140	324383	SIDE COVER	1	
141	949215	MACHINE SCREW M4X8 (10 PCS.)	2	
142	949429	BOLT WASHER M4 (10 PCS.)	2	
143	324415	BUSHING	2	
144	324414	BALL BUSHING	2	
145	324413	HOLDER (A)	1	
146	324418	KNOB BOLT M6X25	2	
147	947859	LOCK SPRING	2	
148	307956	SEAL LOCK HEX. SOCKET SET SCREW M6X10	2	
149	324465	SLIDE PIPE (A)	1	
150	877839	SEAL LOCK HEX. SOCKET HD. BOLT M5X10	1	
151	324388	SLEEVE	1	
152A	310898	SPRING	1	
153	305180	CLUTCH SCREW	1	
154	305179	CLUTCH SPRING	1	
156A	325298	CLAMP LEVER	1	
157	323903	BOLT M8X65	1	
158	949433	BOLT WASHER M8 (10 PCS.)	1	
159	949782	HEX. SOCKET HD. BOLT M6X50 (10 PCS.)	2	
160	323904	STOPPER HOLDER (C)	1	
161	323905	STOPPER (C)	1	
162	324420	SET PIN (A)	1	
163	935196	MACHINE SCREW (W/WASHERS) M4X12 (BLACK)	2	
164	321329	INDICATOR	2	
165		CAUTION LABEL (B)	1	
166	324466	SLIDE PIPE (B)	1	
172	305558	TAPPING SCREW (W/FLANGE) D5X25 (BLACK)	1	FOR USA.CAN
173	324467	HINGE (A)	1	

Parts

C12RSH

ITEM NO.	CODE NO.	DESCRIPTION	NO. USED	REMARKS
174	324421	GRIP	1	
175	307294	MACHINE SCREW (W/WASHERS) M5X16 (BLACK)	1	
176	324372	GUARD ASS'Y	1	INCLUD.172 FOR USA.CAN
179	949215	MACHINE SCREW M4X8 (10 PCS.)	1	
180	949429	BOLT WASHER M4 (10 PCS.)	1	
181	320183	COVER	1	
182	324419	STOPPER PIN ASS'Y	1	INCLUD.183
183	872645	O-RING (P-9)	1	
184	949215	MACHINE SCREW M4X8 (10 PCS.)	1	
185	949429	BOLT WASHER M4 (10 PCS.)	1	
186A	324387	HINGE SHAFT (A)	1	
187A	323606	BASE RUBBER	1	
188	949237	MACHINE SCREW M5X12 (10 PCS.)	1	
189	303854	SPACER	1	
*190	324376	LINK	1	FOR USA.CAN
*190	328522	LINK	1	FOR EUROPE.AUS.NZL
191	319270	ADJUSTER	1	
193	305180	CLUTCH SCREW	1	
194	305179	CLUTCH SPRING	1	
195	962614	ADJUSTING WASHER (B) T0.5	1	
196	319268	PLATE (B)	1	
197	305179	CLUTCH SPRING	1	
198B	329863	LASER MARKER	1	
199	319267	SPRING	2	
200	319541	SEAL LOCK HEX. SOCKET SET SCREW M5X6	2	
201	319271	COVER (A)	1	
202	322291	PLATE (A)	1	
203		CAUTION LABEL (J)	1	
204	949429	BOLT WASHER M4 (10 PCS.)	3	
205	949217	MACHINE SCREW M4X12 (10 PCS.)	3	
206	319267	SPRING	1	
207	319269	HOLDER (B)	1	
231	324460	HANDLE (L)	1	
232	305558	TAPPING SCREW (W/FLANGE) D5X25 (BLACK)	4	
*233	323978	SWITCHING POWER SUPPLY	1	
*233	322911	SWITCHING POWER SUPPLY	1	FOR USA.CAN
*233	324322	SWITCHING POWER SUPPLY	1	FOR GBR (110V).TPE
234	984750	TAPPING SCREW (W/FLANGE) D4X16	3	
*235	500234Z	CORD	1	(CORD ARMOR D10.1)
*235	500247Z	CORD	1	(CORD ARMOR D10.1) FOR NOR.SWE.FIN.DEN
*235	500461Z	CORD	1	(CORD ARMOR D10.1) FOR GBR (110V)
*235	500435Z	CORD	1	(CORD ARMOR D10.1) FOR GBR (230V)
*235	500447Z	CORD	1	(CORD ARMOR D10.1) FOR SUI.LIB
*235	500453Z	CORD	1	(CORD ARMOR D10.1) FOR USA.CAN
*235	500439Z	CORD	1	(CORD ARMOR D10.1) FOR AUS.NZL
*235	500456Z	CORD	1	(CORD ARMOR D10.1) FOR CHN
*235	500474Z	CORD	1	(CORD ARMOR D10.1) FOR TPE
*235	500423Z	CORD	1	(CORD ARMOR D10.1) FOR SIN.UAE.MAL
*235	500468Z	CORD	1	(CORD ARMOR D10.1) FOR THA.PHI
237	319349	CORD BUSH	1	
238	324461	HANDLE (R)	1	
239	938051	CORD ARMOR D10.1	1	
240	937631	CORD CLIP	1	
241	301653	TAPPING SCREW (W/FLANGE) D4X20 (BLACK)	6	
242	880734	MACHINE SCREW (W/WASHERS) M5X25 (BLACK)	5	
243	945161	BRUSH CAP	2	
*244	999038	CARBON BRUSH (1 PAIR)	2	FOR 110V-120V, FOR USA.CAN
*244	999065	CARBON BRUSH (1 PAIR)	2	FOR 220V-240V
245	938241	BRUSH HOLDER	2	
246		CAUTION LABEL (A)	1	FOR USA.CAN

Parts

C12RSH

ITEM NO.	CODE NO.	DESCRIPTION	NO. USED	REMARKS
247		NAME PLATE	1	
248	990541	MACHINE SCREW (W/WASHERS) M5X16	2	
249	324445	TAIL COVER	1	
250	938477	HEX. SOCKET SET SCREW M5X8	2	
251	324459	HOUSING ASS'Y	1	INCLUD.245.248-250
252	937623	BRUSH TERMINAL	2	
*253	340626D	STATOR ASS'Y 110V	1	INCLUD.252
*253	340626C	STATOR ASS'Y 120V	1	INCLUD.252, FOR USA.CAN
*253	340703E	STATOR (B) ASS'Y 220V-230V	1	INCLUD.252
*253	340693E	STATOR ASS'Y (C) 230V	1	INCLUD.252 FOR NZL
*253	340703F	STATOR (B) ASS'Y 240V	1	INCLUD.252
254	324397	END PLATE	1	
255	953121	HEX. HD. TAPPING SCREW D5X50	2	
*256	360790B	ARMATURE ASS'Y 220V-230V	1	INCLUD.257.259.307-309
*256	360790C	ARMATURE ASS'Y 240V	1	INCLUD.257.259.307-309
256A	360711U	ARMATURE ASS'Y 110V-120V	1	INCLUD.257.259.307-310, FOR USA.CAN
257	6000VV	BALL BEARING 6000VVCMP2L	1	
258	324442	FAN GUIDE	1	
259	6201VV	BALL BEARING 6201VVCMP2L	1	
262	976706	MACHINE SCREW (W/WASHERS) M5X10	1	
263	324448	SWITCH HANDLE (L)	1	
264	996247	MACHINE SCREW (W/WASHERS) M5X12 (BLACK)	2	
265	324462	SPINDLE COVER	1	
266	324425	INTERNAL WIRE (A)	1	
*266	326827	INTERNAL WIRE (A)	1	FOR NZL
*267	959141	CONNECTOR 50092 (10 PCS.)	2	
*267	959141	CONNECTOR 50092 (10 PCS.)	1	FOR NZL
*267	959141	CONNECTOR 50092 (10 PCS.)	4	FOR USA.CAN
268	324424	SWITCH (3P FASTON TYPE) W/O LOCK	1	
269	324449	SWITCH HANDLE (R)	1	
270	961468	KNOB BOLT M6X37	1	
271	988821	LOCK SPRING	2	
272	322314	STOPPER HOLDER	1	
273	322313	SPRING PLATE	1	
274	303410	NYLOCK BOLT M8X40	1	
275	324437	GEAR CASE	1	
276	949217	MACHINE SCREW M4X12 (10 PCS.)	1	
277	949429	BOLT WASHER M4 (10 PCS.)	1	
278	973313	NYLON CLIP	1	
279	949260	MACHINE SCREW M6X25 (10 PCS.)	1	
280	606ZZM	BALL BEARING 606VV	2	
281	949455	SPRING WASHER M6 (10 PCS.)	1	
282	949425	WASHER M6 (10 PCS.)	1	
283	935196	MACHINE SCREW (W/WASHERS) M4X12 (BLACK)	1	
284	988101	BOLT (A) M10	1	
285B	323652	WASHER (B)	1	EXCEPT FOR EUROPE
*286		TCT SAW BLADE 305MM-D30 HOLE-NT60	1	
*286	726100	TCT SAW BLADE 305MM-D25.4 HOLE-NT60	1	
*286	726101	TCT SAW BLADE 305MM-D25.4 HOLE-NT90	1	
287	324452	WASHER (A)	1	EXCEPT FOR EUROPE
288	949322	FLAT HD. SCREW M4X10 (10 PCS.)	2	
289	307731	COVER	1	
*290	324375	PROTECTIVE COVER	1	FOR USA.CAN
*290	328523	PROTECTIVE COVER	1	TILL 8.2012 FOR EUROPE
290A	336341	PROTECTIVE COVER	1	SINCE 9.2012 FOR EUROPE
291A	328188	RETURN SPRING (B)	1	
292	324438	SPINDLE ASS'Y	1	INCLUD.293-295
293	6003DD	BALL BEARING 6003DD	1	
294	324439	BEARING HOLDER	1	
295	608VVM	BALL BEARING 608VVC2PS2L	1	

