

ELECTRIC TOOL PARTS LIST

■ SLIDE DUAL COMPOUND MITER SAW
Model C 10FSH / S

2019 • 06 • 20
(E3b)

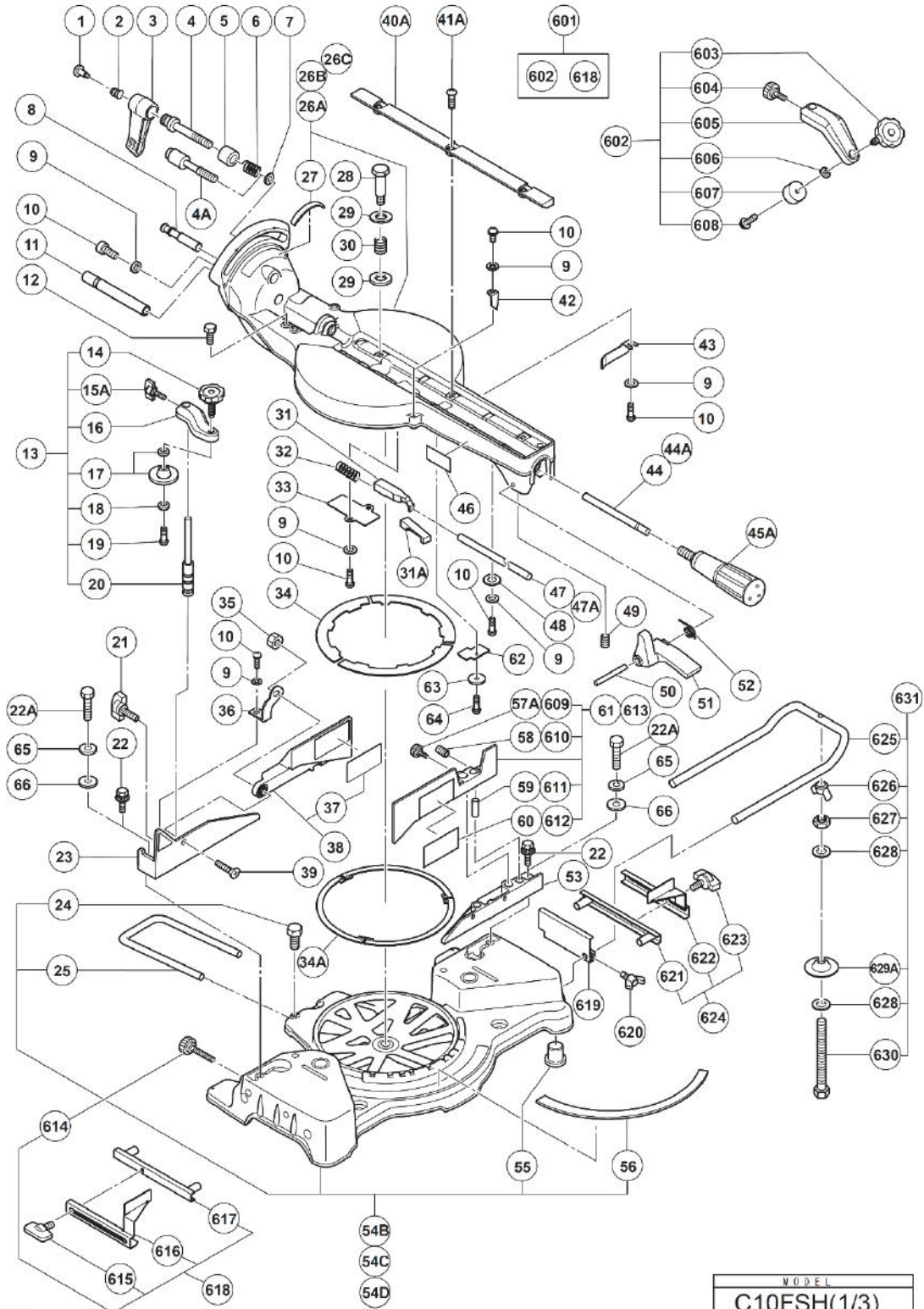

Rev.7

MODEL
C10FSH(1/3)

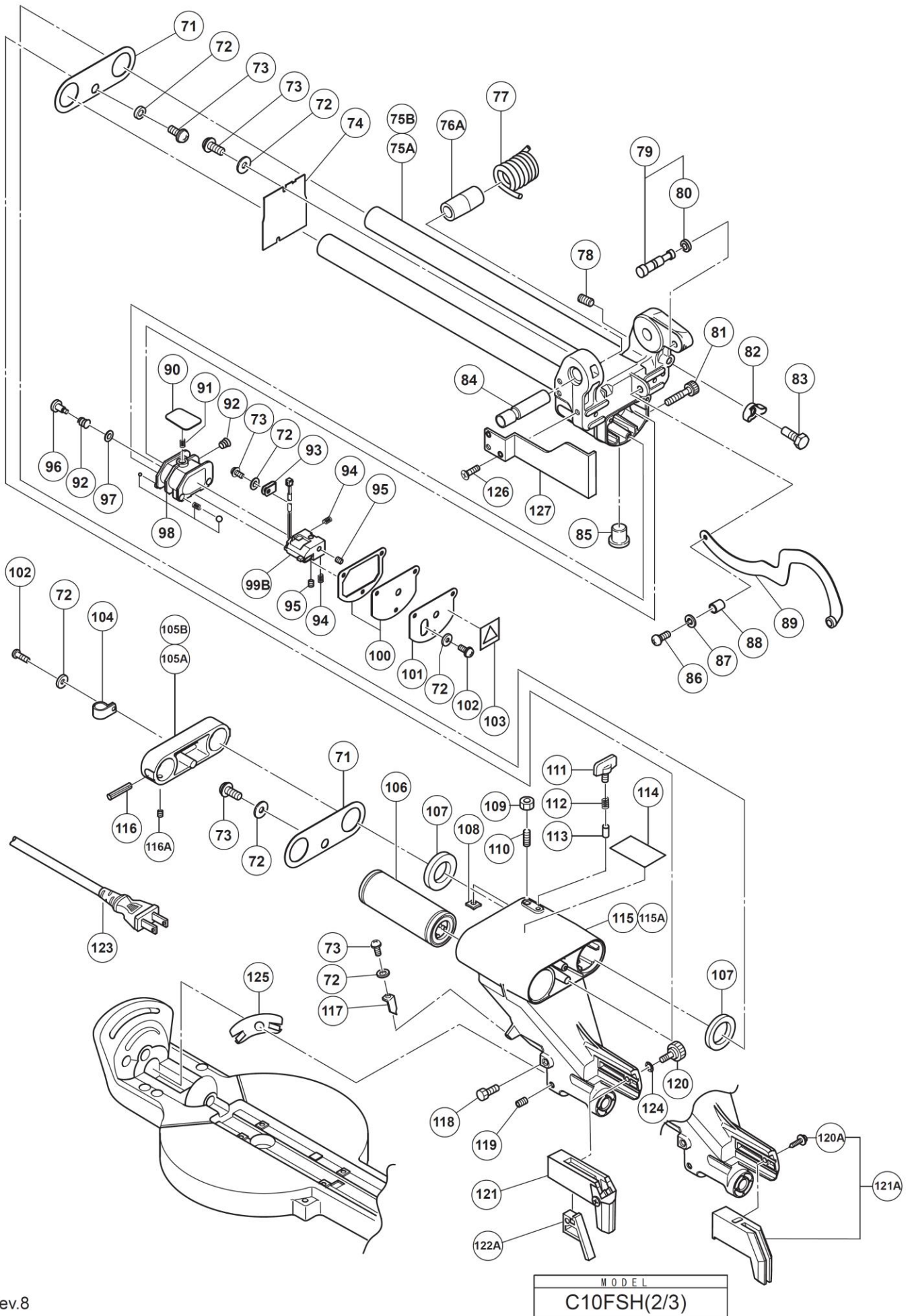

Rev.8

MODEL
C10FSH(2/3)

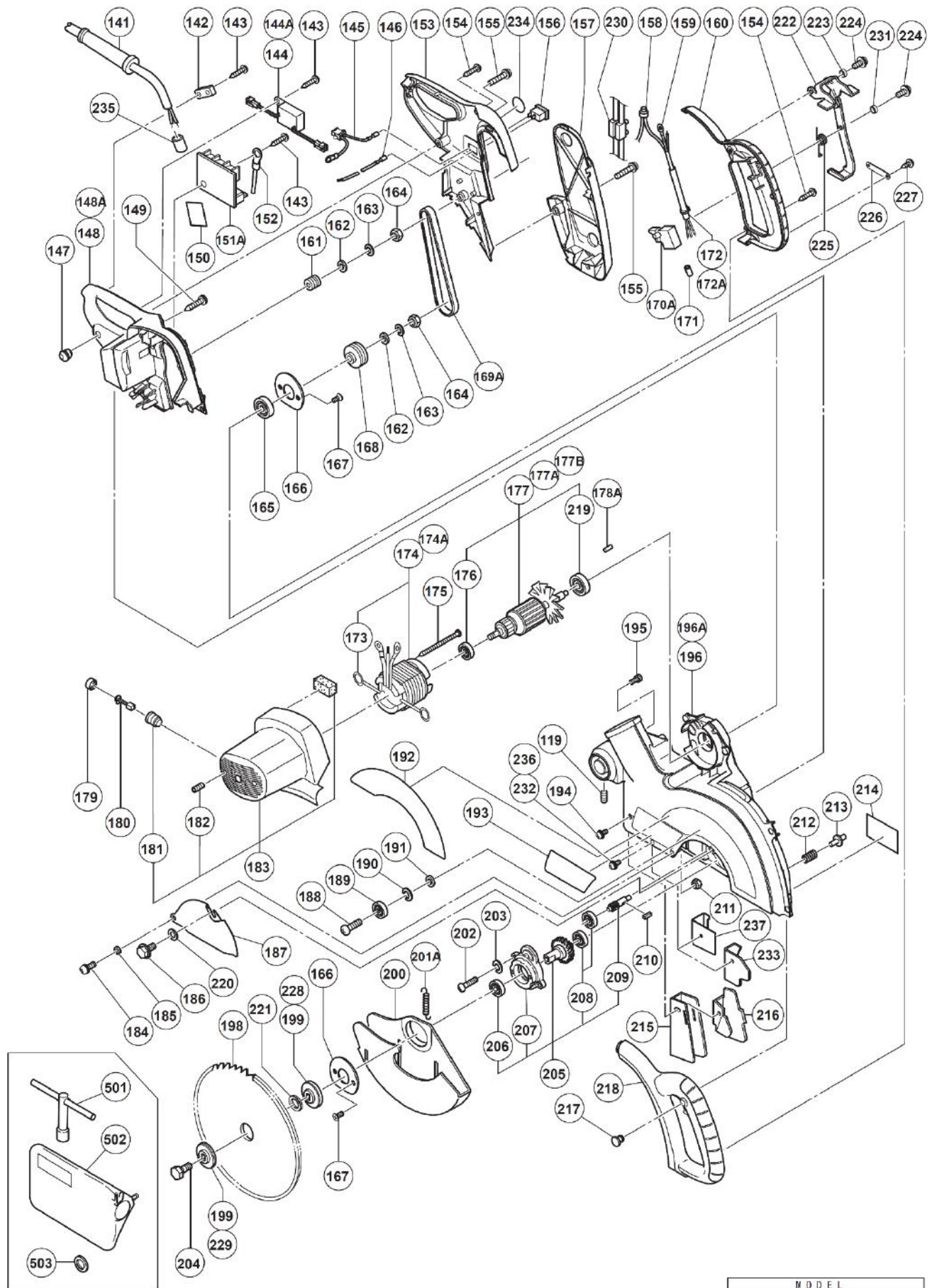

Rev.11

MODEL
C10FSH(3/3)

PARTS

C10FSH / S

ITEM NO.	CODE NO.	DESCRIPTION	NO. USED	REMARKS
1	305180	CLUTCH SCREW	1	
2	305179	CLUTCH SPRING	1	
3	312488	CLAMP LEVER	1	
4	307725	BOLT (LEFT HAND) M10	1	(TILL 08.2010)
4A	329409	BOLT (LEFT HAND) D10	1	(SINCE 09.2010)
5	315195	SLEEVE	1	
7	965077	SPECIAL WASHER	1	
8	321330	SET PIN (A)	1	
*9	949429	BOLT WASHER M4 (10 PCS.)	8	
*9	949429	BOLT WASHER M4 (10 PCS.)	10	SINCE 01.2019 FOR USA.CAN.MODEL(S)
*10	949215	MACHINE SCREW M4X8 (10 PCS.)	8	
*10	949215	MACHINE SCREW M4X8 (10 PCS.)	10	SINCE 01.2019 FOR USA.CAN.MODEL(S)
11	320141	HINGE SHAFT (A)	1	
12	303409	NYLOCK BOLT M8X25	2	
13	321370	WISE ASS'Y	1	INCLUD.14-20
14	308396	KNOB BOLT M10	1	
15A	307947	WING BOLT M6X12	1	
16		SCREW HOLDER	1	
17	319974	WISE PLATE SET	1	
18	996722	WASHER	1	
19	996247	MACHINE SCREW (W/WASHERS) M5X12 (BLACK)	1	
20	321371	WISE SHAFT	1	
21	302459	WING BOLT M6X17	1	
22	307221	BOLT (W/WASHERS) M8X35 (BLACK)	4	(TILL 08.2010)
22A	949678	BOLT M8X35 (10 PCS.)	4	(SINCE 09.2010)
23	321346	FENCE (B)	1	
24	949610	BOLT M6X10 (10 PCS.)	1	
25	998844	HOLDER	1	
*26A	330768	TABLE ASS'Y	1	INCLUD.9.10.27-34A.41A.43.44A.47A-52. 54B.62-64 (TILL 01.2012 FOR USA.CAN).
*26D	375134	TABLE ASS'Y	1	INCLUD.9.10.24.25.27-30.31A-34A.40A.41A.43.44A.47A-52. 54D.55.56.62-64.246, SINCE 02.2012 FOR USA.CAN.MODEL(S)
27	321343	SCALE (B)	1	
28	312480	SHAFT (B)	1	
29	949437	BOLT WASHER M12 (10 PCS.)	2	
30	312481	SPRING	1	
31	321335	STOPPER (A)	1	(TILL 08.2008)
31A	322280	STOPPER (A)	1	(SINCE 09.2008)
32	321417	SPRING (E)	1	
33	321336	PIN COVER	1	
34	998811	LINER	3	(TILL 08.2008)
34A	324400	LINER	3	(SINCE 09.2008)
35	311144	NYLON NUT M6	1	
36	321331	PLATE	1	
37	321386	WARNING LABEL (H)	1	
38	321385	SUB FENCE (B) ASS'Y	1	INCLUD.37
39	949342	FLAT HD. SCREW M6X25 (10 PCS.)	1	
*40A	329421	TABLE INSERT	2	SINCE 02.2012 FOR USA.CAN
*40A	337817	TABLE INSERT	2	EXCEPT FOR USA.CAN (TILL 01.2012 FOR USA.CAN)
41A	949256	MACHINE SCREW M6X16 (10 PCS.)	6	
42	321329	INDICATOR	1	
43	321342	SPACER (A)	1	
44	321341	SHAFT (A)	1	(TILL 08.2008)
44A	329416	SHAFT (A)	1	(SINCE 09.2008)
45A	322283	SIDE HANDLE	1	
46		CAUTION LABEL (K)	1	
47	321337	SHAFT (C)	1	(TILL 08.2008)
47A	329415	SHAFT (C)	1	(SINCE 09.2008)
48	875249	THRUST WASHER	2	
49	987860	SEAL LOCK HEX. SOCKET SET SCREW M6X6	1	
50	321339	LEVER SHAFT	1	
51	321338	LEVER	1	
52	321340	SPRING (D)	1	

PARTS

C10FSH / S

ITEM NO.	CODE NO.	DESCRIPTION	NO. USED	REMARKS
*53	321345	FENCE (A)	1	TILL 12.2018 FOR USA.CAN
*53A	375135	FENCE (A)	1	SINCE 01.2019 FOR USA.CAN.MODEL(S)
54B	330768	TABLE ASS'Y	1	INCLUD.9.10.26A-34A.40.41A.43.44A. 47A-52.62-64 (TILL 01.2012 FOR USA.CAN)
*54D	375134	TABLE ASS'Y	1	INCLUD.9.10.24.25.26D-30.31A-34A.40A.41A.43.44A. .47A-52.55.56.62-64.246,SINCE 02.2012 FOR USA.CAN.MODEL(S)
55	312672	BASE RUBBER	4	
56	315210	SCALE (A)	1	
62	324395	COVER (B)	1	(SINCE 09.2008)
63	949429	BOLT WASHER M4 (10 PCS.)	1	(SINCE 09.2008)
64	949215	MACHINE SCREW M4X8 (10 PCS.)	1	(SINCE 09.2008)
65	949457	SPRING WASHER M8 (10 PCS.)	1	
66	949433	BOLT WASHER M8 (10 PCS.)	1	
70	949215	MACHINE SCREW M4X8 (10 PCS.)	1	
71	996227	PACKING COVER	2	
72	949429	BOLT WASHER M4 (10 PCS.)	11	
73	949215	MACHINE SCREW M4X8 (10 PCS.)	6	
74	321349	COVER	1	
*75A	332813	HINGE (A) ASS'Y	1	INCLUD.105A.116A TILL 01.2012 FOR USA.CAN
*75B	334459	HINGE (A) ASS'Y	1	INCLUD.105A.116A SINCE 02.2012 FOR USA.CAN
76A	334337	SLEEVE	1	
77	321332	SPRING	1	
78	961554	HEX. SOCKET SET SCREW M8X10	1	
79	302518	STOPPER PIN ASS'Y	1	INCLUD.80
80	984528	O-RING (P-6)	1	
81	319270	ADJUSTER	1	
82	949312	WING NUT M8 (10 PCS.)	1	
83	949633	BOLT M8X50 (10 PCS.)	1	
84	320141	HINGE SHAFT (A)	1	
85	312672	BASE RUBBER	1	
86	949237	MACHINE SCREW M5X12 (10 PCS.)	1	
87	949454	SPRING WASHER M5 (10 PCS.)	1	
88	998980	SPACER	1	
*89	321368	LINK	1	FOR USA.CAN
90	319268	PLATE (B)	1	
91	319267	SPRING	1	
92	305179	CLUTCH SPRING	2	
93	980523	NYLON CLIP	1	
94	319267	SPRING	2	
95	319541	SEAL LOCK HEX. SOCKET SET SCREW M5X6	2	
96	305180	CLUTCH SCREW	1	
97	962614	ADJUSTING WASHER (B) T0.5	1	
98	319269	HOLDER (B)	1	
99B	329863	LASER MARKER	1	
100	319271	COVER (A)	1	
101	319272	PLATE (A)	1	
102	949217	MACHINE SCREW M4X12 (10 PCS.)	5	
103		CAUTION LABEL (J)	1	
*104	948193	NYLON CLIP	1	FOR USA.CAN
*105A	331419	SUPPORT	1	EXCEPT FOR USA.CAN (TILL 01.2012 FOR USA.CAN)
*105B	334458	SUPPORT	1	SINCE 02.2011 FOR USA.CAN
106	321347	BALL BUSHING	1	
107	996226	FELT	2	
108	996223	BUSHING	2	
109	949568	LOCK NUT M8 (10 PCS.)	2	
110	974500	HEX. SOCKET SET SCREW M8X16	2	
111	302459	WING BOLT M6X17	1	
112	947859	LOCK SPRING	1	
113	963174	CLAMP PIECE (B)	1	
114	320206	CAUTION LABEL (A)	1	
*115	321375	HOLDER (A)	1	EXCEPT FOR USA.CAN (TILL 01.2012 FOR USA.CAN)
*115A	334462	HOLDER (A)	1	SINCE 02.2012 FOR USA.CAN
116	949686	ROLL PIN D6X40 (10 PCS.)	2	(TILL 08.2010)
116A	961554	HEX. SOCKET SET SCREW M8X10	2	(SINCE 09.2010)
117	321329	INDICATOR	2	

PARTS

C10FSH / S

ITEM NO.	CODE NO.	DESCRIPTION	NO. USED	REMARKS
118	303409	NYLOCK BOLT M8X25	1	
119	307956	SEAL LOCK HEX. SOCKET SET SCREW M6X10	2	
*120	302503	KNOB BOLT M6X22	1	SINCE 01.2019 FOR USA.CAN.MODEL(S)
*120A	305558	TAPPING SCREW (W/FLANGE) D5X25 (BLACK)	1	TILL 12.2018 FOR USA.CAN
*121	321333	GUARD (A)	1	SINCE 01.2019 FOR USA.CAN.MODEL(S)
*121A	324372	GUARD ASS'Y	1	INCLUD.120A TILL 12.2018 FOR USA.CAN
*122A	331845	GUARD HOLDER	1	SINCE 01.2019 FOR USA.CAN.MODEL(S)
*123	500241Z	CORD	1	FOR USA.CAN
*124	960092	WAVE WASHER	1	FOR USA.CAN
125	322210	LINER (A)	1	
141	938051	CORD ARMOR D10.1	1	
142	937631	CORD CLIP	1	
143	984750	TAPPING SCREW (W/FLANGE) D4X16	4	
*144	321378	SWITCHING POWER SUPPLY	1	FOR 110V-127V
*145	321376	CONNECTOR (B)	1	FOR USA.CAN
146	321377	INTERNAL WIRE	1	
147	319349	CORD BUSH	1	
*148A	333985	HANDLE (L)	1	FOR USA.CAN
149	305558	TAPPING SCREW (W/FLANGE) D5X25 (BLACK)	3	
150	321355	SHEET	1	
*151A	321354	CONTROLLER 100V-120V	1	TILL 12.2018 FOR USA.CAN
*151B	375136	CONTROLLER 120V	1	SINCE 01.2019 FOR USA.CAN.MODEL(S)
152	930804	TERMINAL M4.0 (10 PCS.)	1	
153	321380	HANDLE (R)	1	
154	301653	TAPPING SCREW (W/FLANGE) D4X20 (BLACK)	6	
155	880734	MACHINE SCREW (W/WASHERS) M5X25 (BLACK)	4	
156	319503	SWITCH (W/COVER)	1	
157	321383	PULLEY COVER	1	
*158	959141	CONNECTOR 50092 (10 PCS.)	2	FOR USA.CAN.AUS.NZL
159	980063	TERMINAL	1	
*160	321381	SWITCH HANDLE (R)	1	FOR USA.CAN (TILL 03.2007 FOR AUS.NZL)
161	321356	PULLEY (A)	1	
162	949426	WASHER M8 (10 PCS.)	2	
163	978559	SUPER LOCK WASHER	2	
164	949558	NUT M8 (10 PCS.)	2	
165	6201VV	BALL BEARING 6201VV	1	
166	307731	COVER	2	
167	949322	FLAT HD. SCREW M4X10 (10 PCS.)	4	
168	321357	PULLEY (B)	1	
169A	332810	BELT (10PH432)	1	
*170	998839	SWITCH (1P PILLAR TYPE) W/LOCK	1	FOR USA.CAN
*171	981373	TUBE (D)	3	FOR USA.CAN
*172A	321532	INTERNAL WIRE (B) ASS'Y	1	INCLUD.159.171 FOR USA.CAN
173	930703	BRUSH TERMINAL	2	
*174	340539D	STATOR ASS'Y 120V	1	INCLUD.173 TILL 5.2011 FOR USA.CAN
*174A	340778D	STATOR ASS'Y 120V-127V	1	INCLUD.173 SINCE 6.2011 FOR USA.CAN
175	953174	HEX. HD. TAPPING SCREW D5X55	2	
176	321399	BALL BEARING 608VVC2NS7L	1	
*177A	360588U	ARMATURE ASS'Y 110V-120V	1	INCLUD.179.219 FOR USA.CAN TILL 5.2011 FOR USA.CAN
*177B	360924U	ARMATURE ASS'Y 120V-127V	1	INCLUD.176.219 SINCE 6.2011 FOR USA.CAN
178A	946362	BEARING LOCK	1	
179	945161	BRUSH CAP	2	
180	999043	CARBON BRUSH (1 PAIR)	2	
*181	958900	BRUSH HOLDER	2	FOR USA.CAN
182	938477	HEX. SOCKET SET SCREW M5X8	2	
*183	321379	HOUSING ASS'Y	1	INCLUD.181.182 FOR USA.CAN
184	996247	MACHINE SCREW (W/WASHERS) M5X12 (BLACK)	1	
185	998980	SPACER	1	
186	996577	BOLT (W/WASHERS) M6X12 (BLACK)	1	
187	318958	SPINDLE COVER	1	
188	949258	MACHINE SCREW M6X20 (10 PCS.)	1	
189	606ZZM	BALL BEARING 606VV	1	
190	949455	SPRING WASHER M6 (10 PCS.)	1	
191	949425	WASHER M6 (10 PCS.)	1	
192		BRAND LABEL	1	

STANDARD ACCESSORIES

C10FSH / S

ITEM NO.	CODE NO.	DESCRIPTION	NO. USED	REMARKS
501	940543	BOX WRENCH 10MM	1	
*502	998845	DUST BAG (BLACK)	1	
*502	322955M	DUST BAG (BLACK)	1	FOR METABOHPPT

OPTIONAL ACCESSORIES

ITEM NO.	CODE NO.	DESCRIPTION	NO. USED	REMARKS
601	321434	CROWN MOLDING VISE ASS'Y	1	INCLUD.602.618
602	321388	VISE (B) ASS'Y	1	INCLUD.603-608
603	321551	KNOB BOLT M10X54	1	
604	998836	KNOB BOLT M6X11	1	
605		SCREW HOLDER (B)	1	
606	306985	WASHER (H)	1	
607	964851	BASE RUBBER	1	
608	304043	MACHINE SCREW (W/WASHERS) M4X10 (BLACK)	1	
*609	960017	KNOB BOLT M6X32	1	FOR USA.CAN.AUS.NZL
*610	987860	SEAL LOCK HEX. SOCKET SET SCREW M6X6	2	FOR USA.CAN.AUS.NZL
*611	321552	PIN	2	FOR USA.CAN.AUS.NZL
*612		WARNING LABEL (L) FOR USA.CAN.AUS.NZL	1	
*613	321387	SUB FENCE (A) ASS'Y	1	INCLUD.609-612 FOR USA.CAN.AUS.NZL
614	960017	KNOB BOLT M6X32	1	
615	301806	WING BOLT M6X15	1	
616		CROWN MOLDING STOPPER (L)	1	
617	321390	CROWN MOLDING STOPPER HOLDER	1	
618	321374	CROWN MOLDING STOPPER (L) ASS'Y	1	INCLUD.614-617
619	974561	STOPPER	1	
620	949404	WING BOLT M6X20 (10 PCS.)	1	
621	321390	CROWN MOLDING STOPPER HOLDER	1	
622		CROWN MOLDING STOPPER (R)	1	
623	301806	WING BOLT M6X15	1	
624	321373	CROWN MOLDING STOPPER (R) ASS'Y	1	INCLUD.614.621-623
625	321549	HOLDER	2	
626	949313	WING NUT M6 (10 PCS.)	2	
627	949556	NUT M6 (10 PCS.)	2	
628	967329	WASHER (H)	4	
629A	322047	VISE PLATE	2	
630	996283	HIGH TENSION BOLT M6X65	2	
631	321553	GUIDE ASS'Y	1	INCLUD.614.619.620.625-630

