

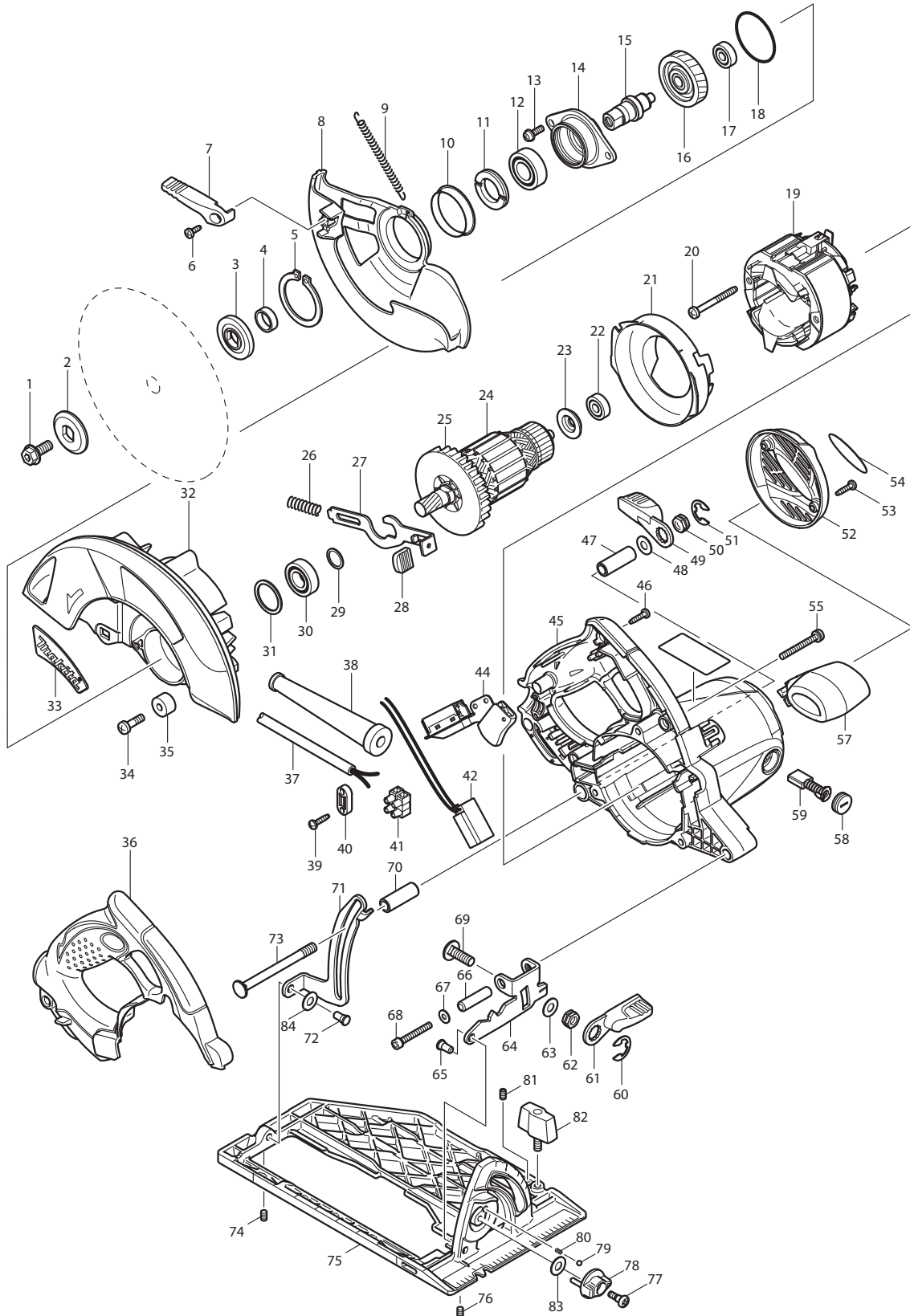

11-2009
5007MG
7-1/4" CIRCULAR SAW, AC



Item No	Type	Ref	Part No	Description	Qty	Unit
001			266283-4	HEX. SOCKET HEX. BOLT M8X20	1	PC.
002	2		224409-4	* OUTER FLANGE 35	1	PC.
003	2		224411-7	* INNER FLANGE 35	1	PC.
004			257279-6	RING 17	1	PC.
005			961201-4	RETAINING RING S-42	1	PC.
006			266398-7	TAPPING SCREW BIND CT 4X12	1	PC.
007			272252-5	LEVER 65	1	PC.
008	3		319780-0	SAFETY COVER	1	PC.
009			231839-2	TENSION SPRING 4	1	PC.
010	1		345422-0	SPACER	1	PC.
	2		346880-3	SPACER	1	PC.
011			285848-3	BEARING RETAINER 23-36	1	PC.
012	2		210301-0	BALL BEARING 6003DDW	1	PC.
013			911223-4	PAN HEAD SCREW M5X16	2	PC.
014			318056-2	BEARING BOX	1	PC.
015			324690-8	SPINDLE	1	PC.
016			226630-1	HELICAL GEAR 47	1	PC.
017	2		211031-6	BALL BEARING 608LLB	1	PC.
018			213623-7	O RING 46	1	PC.
019			596286-7	FIELD ASS'Y 115V	1	PC.
		INC.	654020-2	RING TERMINAL	2	PC.
		INC.	654502-4	CONNECTOR P-2	2	PC.
020			266397-9	TAPPING SCREW BIND 5X50	2	PC.
021			419548-5	BAFFLE PLATE	1	PC.
022	2		211031-6	BALL BEARING 608LLB	1	PC.
023			681625-5	INSULATION WASHER	1	PC.
024			516976-6	ARMATURE ASS'Y 115V	1	PC.
		INC.		Item No. 22,23,25,29,30		
025			240003-4	FAN 80	1	PC.
026			231297-2	COMPRESSION SPRING 9	1	PC.
027			345717-1	SHAFT LOCK	1	PC.
028			286275-7	CAP	1	PC.
029			267280-3	FLAT WASHER 15	1	PC.
030			211236-8	BALL BEARING 6002DDW	1	PC.
031			261132-0	URETHANE WASHER 26	1	PC.
032	1		188176-4	BLADE CASE SET	1	PC.
		INC.	263002-9	RUBBER PIN 4	2	PC.
		INC.	816845-4	SCALE PLATE	1	PC.
		INC.		Item No.33		
	2		183L21-0	BLADE CASE SET	1	PC.
		INC.	263002-9	RUBBER PIN 4	2	PC.
		INC.	816845-4	SCALE PLATE	1	PC.
		INC.		Item No.33		
033			819234-2	MAKITA LOGO PLATE	1	PC.
034			251247-1	+ PAN HEAD SCREW M6X20	1	PC.
035	2		262502-6	RUBBER SLEEVE 6	1	PC.
036			419553-2	HANDLE COVER	1	PC.
037			551187-6	CORD W/PLUG,GUARD 2P-14-2.6M,SJ	1	PC.
		INC.		Item No. 38		
038			682564-2	CORD GUARD	1	PC.
039			266326-2	TAPPING SCREW 4X18	2	PC.
040			687124-5	STRAIN RELIEF	1	PC.
041			654531-7	TERMINAL BLOCK 2P	1	PC.
042			631709-9	LIGHT CIRCUIT	1	PC.
044			651189-3	SWITCH TG933TN-2	1	PC.

Item No	Type	Ref	Part No	Description	Qty	Unit
045			158099-0	MOTOR HOUSING COMPLETE	1	PC.
		INC.	643653-8	BRUSH HOLDER 6.5-13.5	2	PC.
046			266326-2	TAPPING SCREW 4X18	5	PC.
047			331719-3	PIPE 9	1	PC.
048			941201-0	FLAT WASHER 8	1	PC.
049			272253-3	LEVER 56	1	PC.
050			252199-9	HEX. NUT M8-13	1	PC.
051			257953-6	BOW STOP RING E-12	1	PC.
052	2		188448-7	* REAR COVER SET	1	PC.
		INC.		* Item No. 54		
053			266326-2	TAPPING SCREW 4X18	2	PC.
054			819237-6	MAKITA LOGO LABEL	1	PC.
055			911268-2	PAN HEAD SCREW M5X45	3	PC.
056			862678-5	NAME PLATE 5007MG	3	PC.
057			419550-8	FRONT GRIP	1	PC.
058			643650-4	BRUSH HOLDER CAP 6.5-13.5	2	PC.
059	2		194986-9	CARBON BRUSH CB-154 2PC/SET W/ ORIGIN	1	SET
060			257953-6	BOW STOP RING E-12	1	PC.
061			272253-3	LEVER 56	1	PC.
062			252199-9	HEX. NUT M8-13	1	PC.
063			941201-0	FLAT WASHER 8	1	PC.
064			345718-9	ANGULAR GUIDE	1	PC.
065	2		256511-5	SHOULDER PIN 6-7	1	PC.
066			257759-2	SLEEVE 6	1	PC.
067			941101-4	FLAT WASHER 5	1	PC.
068			922261-1	HEX. SOCKET HEAD BOLT M5X40	1	PC.
069			266396-1	FLAT HEADSQUARE NECKBOLT M8X24	1	PC.
070			331719-3	PIPE 9	1	PC.
071			345719-7	DEPTH GUIDE	1	PC.
072	2		256511-5	SHOULDER PIN 6-7 (Grove is added)	1	PC.
073			266237-1	CAP SQUARE NECK BOLT M8X90	1	PC.
074			266229-0	H.S.SET SCREW(CUP POINT)M5X8	1	PC.
075			158101-9	BASE COMPLETE	1	PC.
		INC.	816846-2	SCALE PLATE	1	PC.
076			266229-0	H.S.SET SCREW(CUP POINT)M5X8	1	PC.
077			251370-2	+ PAN HEAD SCREW G5	1	PC.
078			419549-3	DIAL 27	1	PC.
079			216008-6	STEEL BALL 4	1	PC.
080			233314-4	COMPRESSION SPRING 4	1	PC.
081			266229-0	H.S.SET SCREW(CUP POINT)M5X8	1	PC.
082			251858-2	SCREW M6X15	1	PC.
083			253811-4	FLAT WASHER 5 (added)	1	PC.
084			253186-1	* FLAT WASHER 7	1	PC.
085			450351-5	* SPACER	2	PC.
C01			848019-9	CARTON F/5007MG	1	PC.
ACCESSORIES			- See catalogue or visit www.makita.ca for optional accessory -			
A01			164095-8	GUIDE RULE	1	PC.
A02			783204-6	HEX. WRENCH 6	1	PC.
A03	2		A-94530-10	7-1/4" FRAMING BLADE, 24T 5/8" 10PC/PK	1	PC.
	Opt.		A-94839-10	7-1/4" FRAMING BLADE 24T, 10/PK	1	PC.
A04	1		824772-1	PLASTIC CARRYING CASE	1	PC.
		INC.	163455-1	LATCH	2	PC.
		INC.	419360-3	HANDLE	1	PC.
	2		158279-8	PLASTIC CARRYING CASE COM. (W/SPONGE)	1	PC.

Item No	Type	Ref	Part No	Description	Qty	Unit
		INC.	163455-1	LATCH	2	PC.
		INC.	419360-3	HANDLE	1	PC.
A05			804584-8	MODEL NO. LABEL	1	PC.
A06			199716-3	DUST NOZZLE SET	1	PC.
		INC.	272258-3	LEVER 37	1	PC.
		INC.	911223-4	PH SCREW M5X16 W/WR	1	PC.

SERVICE CHANGES

1. Changes on Outer & Inner Flange

Item No.	Description	Type 1	Type 2
2	Outer Flange (Dia.40 mm > 35 mm)	224403-6	224409-4
3	Inner Flange (Dia.40 mm > 35 mm)	224151-7	224411-7

Above parts are completely interchangeable as a set.

2. Changes on Rear Cover Set

Item No.	Description	Type 1	Type 2
52	Rear Cover Set	188178-0	188448-7
85	Spacer	-----	450351-5

Above parts are completely interchangeable as a set.

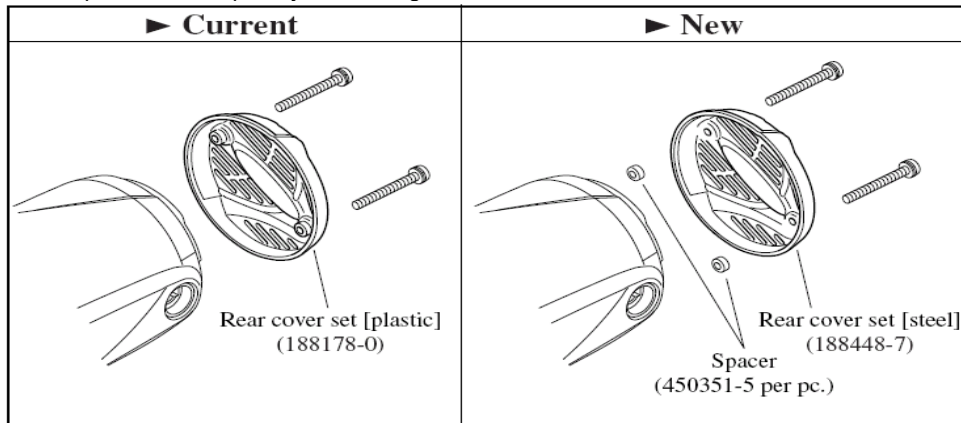

3. Changes on Flat Washer 7

Item No.	Description	Type 1	Type 2	Type 3
84	Flat Washer 7	-----	253186-1	-----

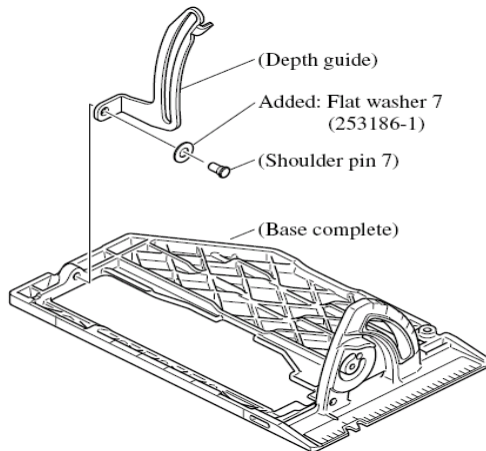

(Type 2 - Tech Info # 77294)

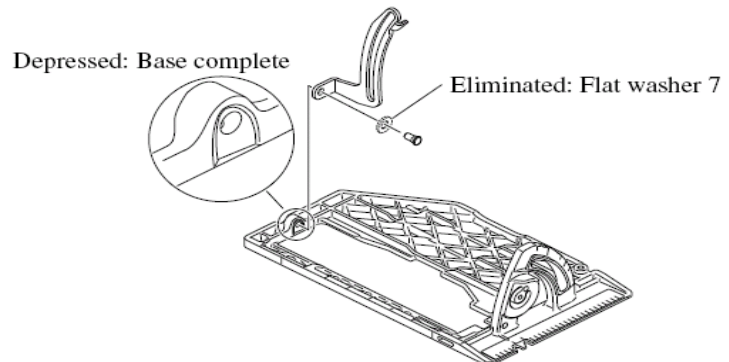

(Type 3 - Tech Info # 81095)